



www.micronicsflowmeters.com

USER'S GUIDE

Installation & Operation
Instructions

Area-Velocity Flow Meter

Model UF AV5500

Manual Series A.1

Note: This page has been left blank intentionally.

INDEX

CONNECTIONS	4
FUNCTION TEST	4
KEYPAD SYSTEM.....	6
CALIBRATION MENU	7
ICONS.....	8
MESSAGE ICON	9
STATUS.....	9
PASSWORD	10
MENU SELECTIONS	11
UNITS/MODE.....	11
CALIBRATION.....	13
RELAY PARAMETERS	18
DATA LOGGING.....	19
COMMUNICATION (OPTIONAL).....	21
SPECIAL FUNCTIONS	22
INSTALLATION – SENSOR LOCATION	24
ENCLOSURE INSTALLATION	31
FIELD TROUBLESHOOTING.....	32
APPLICATIONS HOTLINE.....	35
PRODUCT RETURN PROCEDURE.....	35
APPENDIX A – OPTIONS.....	37
MODBUS® COMMUNICATION.....	43
SPECIFICATIONS	58

IMPORTANT NOTE: This instrument is manufactured and calibrated to meet product specifications. Please read this manual carefully before installation and operation. Any unauthorized repairs or modifications may result in a suspension of the warranty.

Available in Adobe Acrobat pdf format



CONNECTIONS

POWER INPUT: 100 to 240 VAC 50/60Hz. No adjustments are necessary for voltages within this range. Connect L (Live) N (Neutral) and AC Ground.

Optional DC: 9-32 VDC. Connect to + and - terminals.

Optional Thermostat and Heater modules are available rated for 115 VAC or 230 VAC.

IMPORTANT NOTE: AC power input and relay connection wires must have conduit entry to the instrument enclosure. Installation requires a switch, overcurrent fuse or circuit breaker in the building (in close proximity to the equipment) that is marked as the disconnect switch.



Risk of electric shock. Loosen cover screw to access connections. Only qualified personnel should access connections.

Note: Use of instrumentation over 40°C ambient requires special field wiring.

Note: User replaceable fuse is 2 Amp 250V (T2AL250V).

FUNCTION TEST:

Connect the sensor to the sensor terminals as shown on next page, then apply power. Allow 30 seconds for the UF AV5500 to initialize.

- A. Place QZ02L sensor (flat to the bottom) in a bucket of water about 6" deep and press the  programming button to view the status page which shows level and velocity. Stir the water to see a velocity reading.

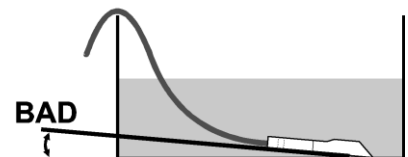
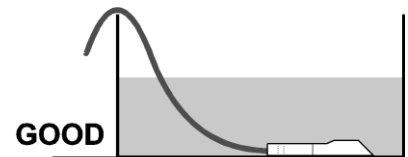

CONNECTIONS

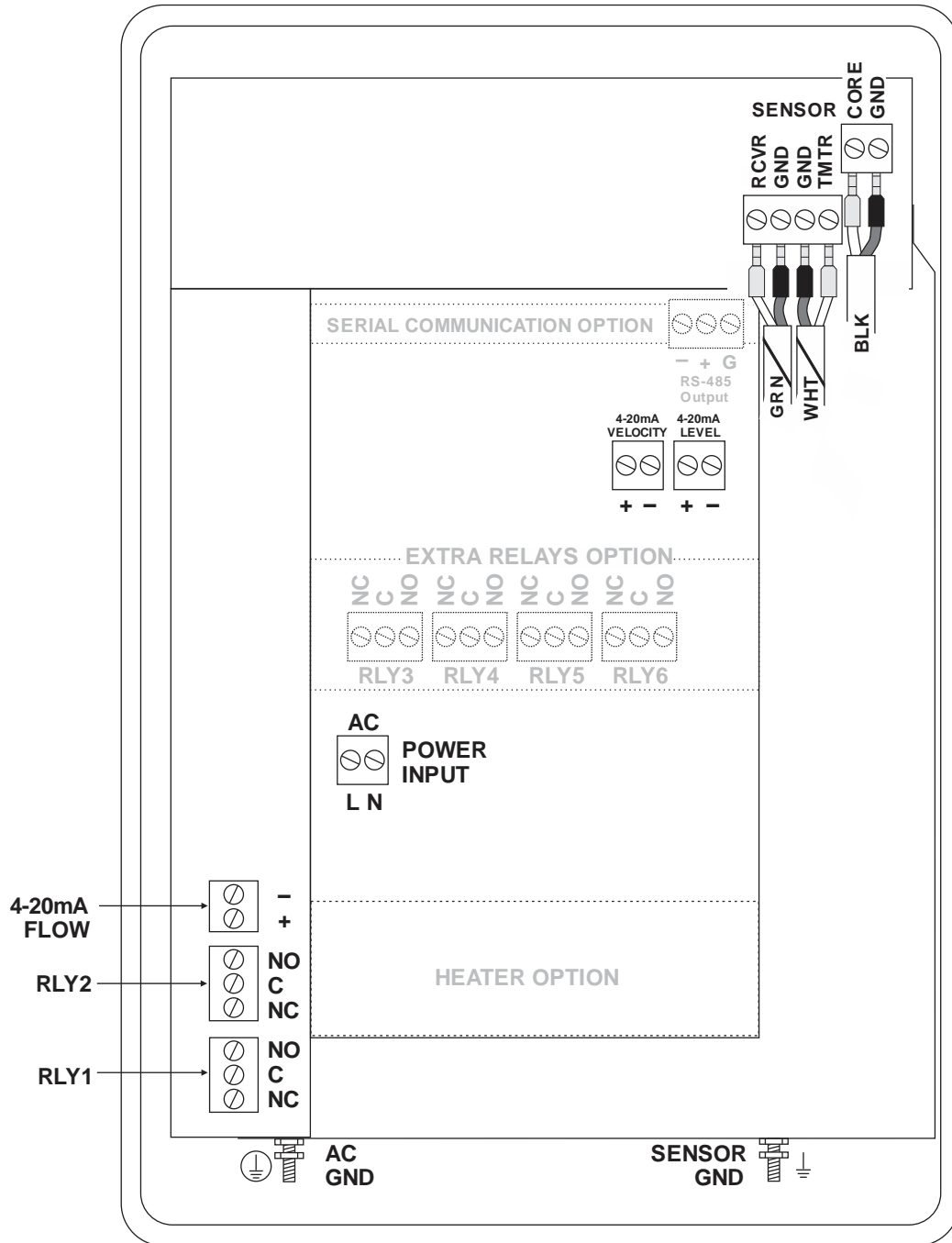

KEYPAD SYSTEM

The UF AV5500 uses a menu system. Arrows show the four directions to leave a menu box. Pressing a corresponding keypad arrow will move to the next item in the direction shown. Move the cursor (underline) under numerals and increase or decrease numerals with the **↑** and **↓** keys.

To store settings permanently (even through power interruptions), press **✓**.

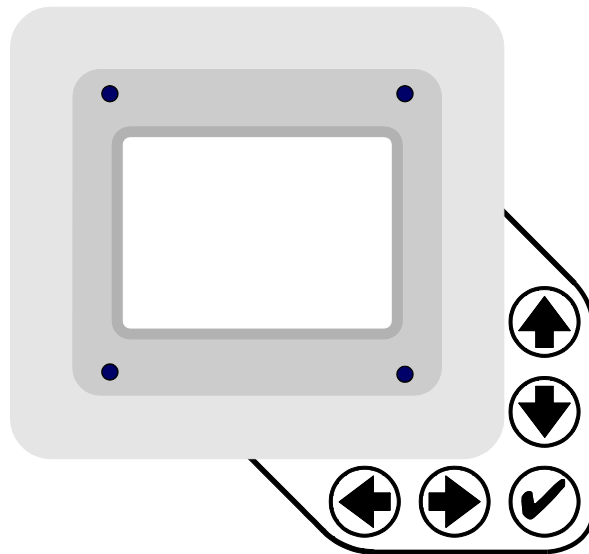

CALIBRATION MENU

<pre> -- Units/Mode----- Mode Flow Li near USG Volume USG Multiplier Velocity ft/s Flow USG/m Temperature C </pre>	<pre> -- Calibration----- Range 180.00 in Max 8.00 in Level 180.00 in Min 1.00 in Min 18.00 in 4mA 0.00 in Velocity 10.00 ft/s 4mA 0.00 ft/s Flow 0.00 gal/m Min 500.00 gal/m 4mA 0.00 gal/m Lvl Offset 0.00 in Signal Cut off 10 % Damping 10 % Level 10 % LOE Time 30 sec Cal Constant 1.000 </pre>	<pre> -- Channel Setup----- Pipe ID 0.7281 </pre>	<pre> -- Relay Parameters-- Relays 1 Function Flow On 1000 USG/m m Off 0.000 USG/m m </pre>	<pre> -- Data Logging----- Log Site ID 0 Mode Flow File Format LG2 Date Feb 27/2019 Interval 11:00 Interval 10sec Data Log Logging </pre>	<pre> -- Communication----- Protocol Modbus Address 001 Baud Rate 9600 Parity Even Stop Bits 1 </pre>	<pre> -- Special Functions- Language English Analog Out 4-20mA Reset Hi Lo Reset Totalizer NO Neg. Totalizer NO Rev. Flow Off Capture Par No Capture Mode No Defaults NO New Password 0000 </pre>	<pre> -- Simulation----- Test Actual Level 0.00 in Velocity 10ft/s Flow 1992.88USG/m 4-20mA Velocity 20.00 4-20mA Flow 20.00 Relays 1 2 3 4 5 6 </pre>	<pre> -- Configuration----- Serial # 000012345 Utility 1.24.0.1 Meter 1.1.1.1 Password 1.1.1.1 Logger 1.24T Relays 6 Analog Out 3 </pre>
--	--	--	--	---	---	--	---	---

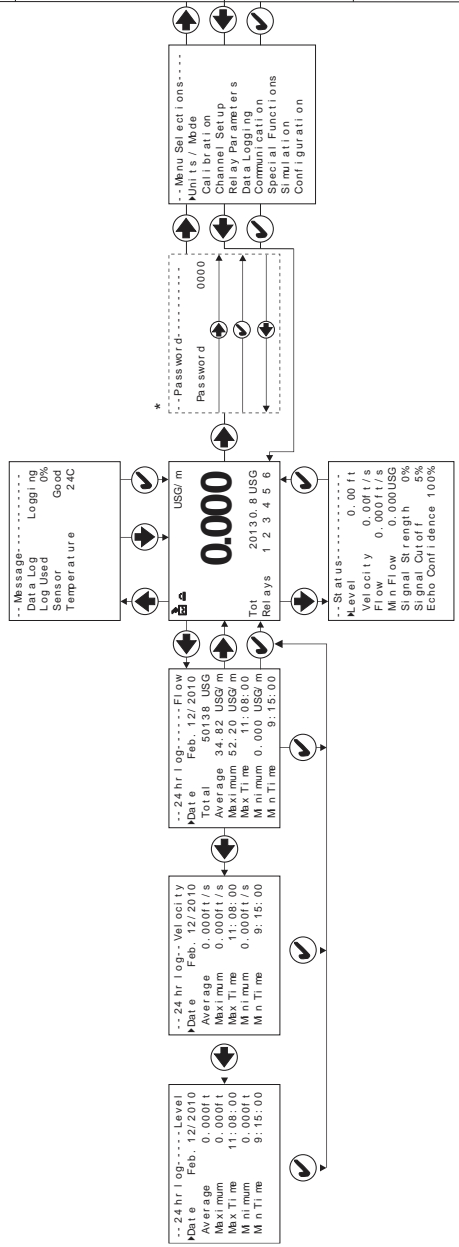

OPTIONAL FEATURES

* Menu only appears if "New Password" has been changed from 0000 in "Special Functions" menu.

ICONS



Message waiting. Press .



Data logging off.



Data logging on.

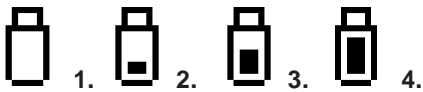

USB file download.



File download completed.



Download Error.



Echo OK.



Dry sensor. No water in pipe/channel.



Echo loss.



Echo OK (PZxx series level sensor option).



No Echo (PZxx series level sensor option).



```
-- Status -----
▶Level          0.00 ft
Velocity        0.00 ft/s
Flow           0.000 ft/s
Min Flow       0.000 USG
Signal Strength 0%
Signal Cut off 5%
Echo Confidence 100%
```

STATUS (cont.)

Echo Confidence

Displays the confidence of level measurement received from the QZ02L submerged sensor, or PZ15 level sensor, on a 0-100% scale. This value is a reflection of the percent of echoes received from pulses. Example: If 8 pulses are sent from the level sensor and only 4 echoes are received, Echo Confidence will report 50%. This does not mean that the level is inaccurate, but instead means the level reading could be susceptible to a loss of reading should the conditions causing missed pulses gets worse. Like an increase in solids or bubbles in the flow steam.

```
--24 hr log-----Flow
▶Date      Feb. 12/2010
Total      50138 USG
Average    34.82 USG/m
Maximum    52.20 USG/m
Max Time   11:08:00
Minimum    0.000 USG/m
Min Time   9:15:00
```

24 HR LOG

Press ◀ from the MAIN display to view a formatted flow report from instruments with a built-in data logger. Press ◀ to pan through Flow, Velocity and Level summaries. Press ↓ to scroll down one day or repeatedly to scroll to a specific date. Up to 365 days can be stored for Flow, Level, and Velocity. Newest date will overwrite the oldest. Press ✓ to return to the main display.

Inserting a USB drive into the meter while on this screen will transfer 24 HR Log data to the USB drive in .csv format.

```
--Password-----
Password          0000
▶
✓
◀
```

PASSWORD

The Password (a number from 0000 to 9999) prevents unauthorized access to the Calibration menu.

From the Main Display press the ▶ key to get to Password. Factory default password is 0000 and if it has not been changed, this screen will be bypassed completely.

A new password can be stored by going to the Special Functions New Password menu.

If a user password is required, press ▶ to place the cursor under the first digit and ↓ or ↑ to set the number, then ▶ to the second digit, etc. Press ▶ or ✓ to proceed to the Menu Selections screen.



```
-- Menu-----
▶Units / Mode
  Calibrati on
  Relay Paramet ers
  Data Loggi ng
  Communi cati on
  Speci al Functi ons
  Si mulati on
  Confi gurati on
```

MENU SELECTIONS

The Menu selections page is used to navigate to specific menus which are described in more detail on the following pages.

Press **↑** or **↓** to navigate to different menus, and **→** to enter the selected menu.

```
--Units/Mode-----
▶ Mode           Flow
  Linear         in
  Volume         USG
  Multiplier     x1
  Velocity       ft/s
  Flow           USG/m
  Temperature    F
```

UNITS/MODE

At Mode, press the **→** and then the **↑** or **↓** to select Flow or Velocity. Flow mode displays the flow rate in engineering units (e.g. gpm, litres/sec, etc.) Press the **✓** to store your selection then the **↓** to the next menu item.

At Linear press the **→** key and then the **↑** or **↓** to select your units of measurement. The Linear units define what units the pipe/channel dimensions and level reading will be displayed in. Typically inches or mm is selected. Press the **✓** to store your selection then the **↓** to the next menu item.

At Volume, press the **→** and then the **↑** or **↓** to select units for volume. Note: “bbl” denotes US oil barrels. Press the **✓** to store your selection then the **↓** to the next menu item.

At Multiplier, press the **→** and then the **↑** or **↓** to select the totalizer multiplier. Multipliers are used when resolution down to single digit is not required, or when you don’t want to convert from gallons to thousands of gallons, as an example. Press **✓** to store your selection then **↓** to the next menu item.

At Velocity, press the **→** and then the **↑** or **↓** to select the engineering units for flow velocity and sonic velocity of the fluid. Press **✓** to store your selection then **↓** to the next menu item.

At Flow, press the **→** and then the **↑** or **↓** to select the engineering units for flow rate. Press **✓** to store your selection then **↓** to the next menu item.

Available Flow Rate Engineering Units:

Abbreviation	Description	Abbreviation	Description
USG/d	US gallons per day	L/d	litres per day
USG/h	US gallons per hour	L/h	litres per hour
USG/m	US gallons per minute	L/m	litres per minute
USG/s	US gallons per second	L/s	litres per second
ft ³ /d	cubic feet per day	m ³ /d	cubic meters per day
ft ³ /h	cubic feet per hour	m ³ /h	cubic meters per hour
ft ³ /m	cubic feet per minute	m ³ /m	cubic meters per minute
ft ³ /s	cubic feet per second	m ³ /s	cubic meters per second
bbbl/d	barrels per day (1 bbl = 42 USG)	IG/d	Imperial gallons per day
bbbl/h	barrels per hour (1 bbl = 42 USG)	IG/d	Imperial gallons per day
bbbl/m	barrels per minute (1 bbl = 42 USG)	IG/d	Imperial gallons per day
bbbl/d	barrels per second (1 bbl = 42 USG)	IG/d	Imperial gallons per day
USMG/d	US million gallons per day	IMG/d	Imperial million gallons per day
USMG/h	US million gallons per hour	IMG/h	Imperial million gallons per hour
USMG/m	US million gallons per minute	IMG/m	Imperial million gallons per minute
USMG/s	US million gallons per second	IMG/s	Imperial million gallons per second

CALIBRATION

```

-- Calibration-----
▶ Range
  Max      180.00 in
  Min      8.00 in
Level
  Max      180.00 in
  Min      1.00 in
  20mA     180.00 in
  4mA      0.00 in
Velocity
  20mA     10.00 ft/s
  4mA      0.00 ft/s
Flow
  Min      0.00 gal/m
  20mA     500.00 gal/m
  4mA      0.00 gal/m
Lvl Offset 0.00 in
Signal Cutoff 10 %
Damping
  Velocity 10 %
  Level    10 %
LOE Time   30 sec
Cal Constant 1.000
  
```

Range Max Only shown when the level sensor used is a through-air PZ type. Max range should be set as the distance from the face of the PZ sensor to the zero level reference point of the pipe/channel it is installed above. See drawing below.

Min Only shown when the level sensor used is a through-air PZ type. Min range should be set as the distance from the face of the PZ sensor to the maximum water level of the pipe/channel it is installed above. The water in the pipe/channel should get no closer than 8 inches for a PZ15-LP sensor type. See drawing below.

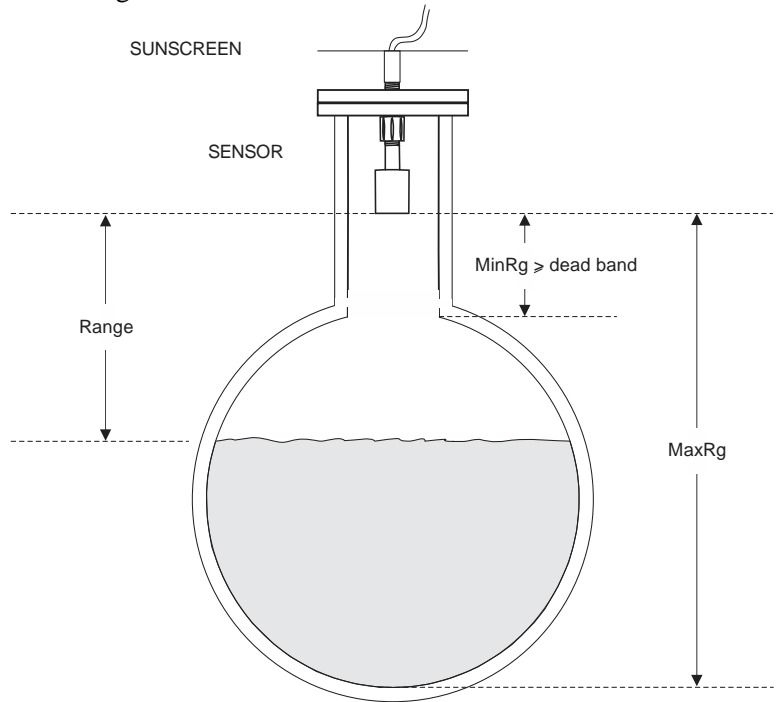

Level Max For QZ02L (submersible, default) level sensor, set the maximum height the level should reach in the system, in units configured in the Units/Mode menu. If a Round pipe is selected in the Channel Setup menu, then this value should be set to the same value as the inside diameter.

Min For QZ02L (submersible, default) level sensor, set the minimum height the level should reach in the system, in units configured in the Units/Mode menu. Minimum level for the QZ02L sensor is 1 inch, however, this value could be set to a larger value if you want to ignore levels greater than 1 inch.

20mA Set the 20mA value for the level analog output, in units configured in the Units/Mode menu.

CALIBRATION (cont.)

-- Calibration-----	
▶ Range	
Max	180.00 in
Min	8.00 in
Level	
Max	180.00 in
Min	1.00 in
20mA	180.00 in
4mA	0.00 in
Velocity	
20mA	10.00 ft/s
4mA	0.00 ft/s
Flow	
Min	0.00 gal/m
20mA	500.00 gal/m
4mA	0.00 gal/m
Lvl Offset	0.00 in
Signal Cut off	10 %
Damping	
Velocity	10 %
Level	10 %
LOE Time	30 sec
Cal Constant	1.000

- 4mA Set the 4mA value for the level analog output, in units configured in the Units/Mode menu.
- Velocity Only shown when Mode = Velocity in the Units/Mode menu. When measured velocity is less than the Min Velocity, the reading on the LCD display and output signals will report 0.
- Min
- 20mA Set the 20mA value for the velocity analog output, in units configured in the Units/Mode menu.
- 4mA Set the 4mA value for the velocity analog output, in units configured in the Units/Mode menu.
- Flow Only shown when Mode = Flow in the Units/Mode menu.
- Min When measured flow is less than the Min Flow, the reading on the LCD display and output signals will report 0.
- 20mA Set the 20mA value for the flow analog output, in units configured in the Units/Mode menu.
- 4mA Set the 4mA value for the flow analog output, in units configured in the Units/Mode menu.
- Lvl Offset For the QZ02L sensor only. Set to 0.00 when sensor is mounted at the bottom of a channel/pipe. When the sensor is mounted above the floor, in order to avoid having the sensor become coated with debris, enter the distance between the floor and the bottom of the sensor.

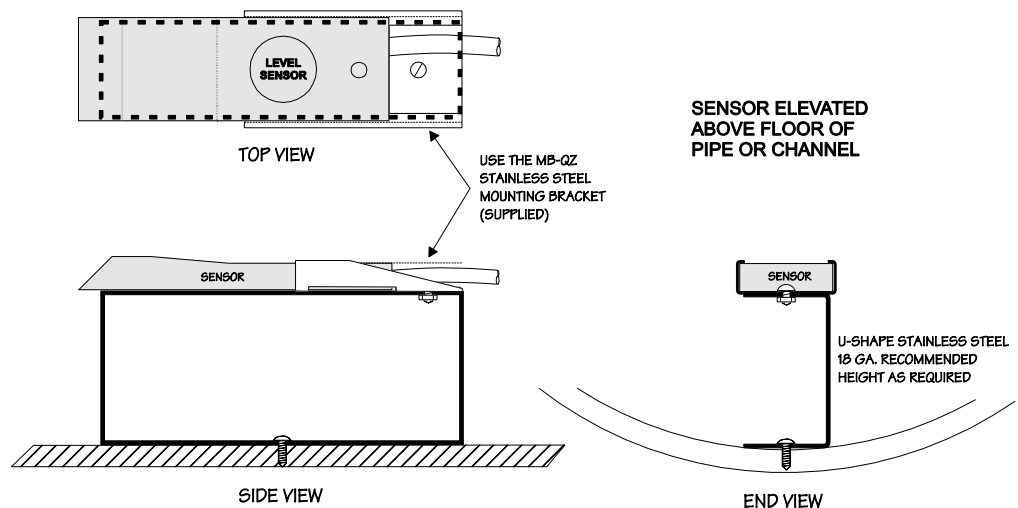

CALIBRATION (cont.)

-- Calibration-----	
▶ Range	
Max	180.00 in
Min	8.00 in
Level	
Max	180.00 in
Min	1.00 in
20mA	180.00 in
4mA	0.00 in
Velocity	
20mA	10.00 ft/s
4mA	0.00 ft/s
Flow	
Min	0.00 gal/m
20mA	500.00 gal/m
4mA	0.00 gal/m
Lvl Offset	0.00 in
Signal Cutoff	10 %
Damping	
Velocity	10 %
Level	10 %
LOE Time	30 sec
Cal Constant	1.000

- Signal Cutoff** Adjust the setting in percent to suppress industrial noise from potentially being read as Doppler signals. When Signal Strength is less than Signal Cutoff, the velocity measurement will report 0.00 on the LCD display.
- Damping Velocity** Set the dampening value for the velocity reading. Lower values provide fast response to changing velocities, and higher values provide a slower response. A value of 0 disables dampening. Factory default value is 10%.
- Level** Set the dampening value for the level reading. Lower values provide fast response to changing levels, and higher values provide a slower response. A value of 0 disables dampening. Factory default value is 10%.
- LOE Time** Should the level reading be lost because of air or debris in the system, the LOE Time will cause the meter to hold the last valid level reading until the LOE Time is expired, at which point the meter will produce a Loss of Echo alarm message. Having a LOE Time in the meter means that intermittent air or debris issues in the system will not cause the meter to lose flow reading. If you desire that the meter respond quickly to a Loss of Echo, set the LOE Time to a low value.
- Cal Constant** Used to scale the velocity output of the meter. Factory default is 1.000.

```

-- Channel Set up-----
▶Type           Round
Pipe I D       0.75ft
  
```

CHANNEL SETUP

- Round Select Round for open pipes. Set Pipe ID to the inner diameter of the pipe.
- Rectangle Select Rectangle for rectangular channels. Enter the channel width.
- Trapezoid Select Trapezoid for trapezoidal shaped channels. Specify the Width and Slope of the channel as shown in the following illustration.

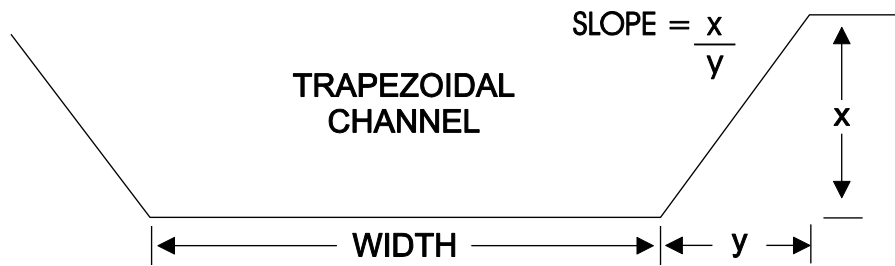

- Egg Select Egg for Egg shaped channels. Enter the Height of the channel.

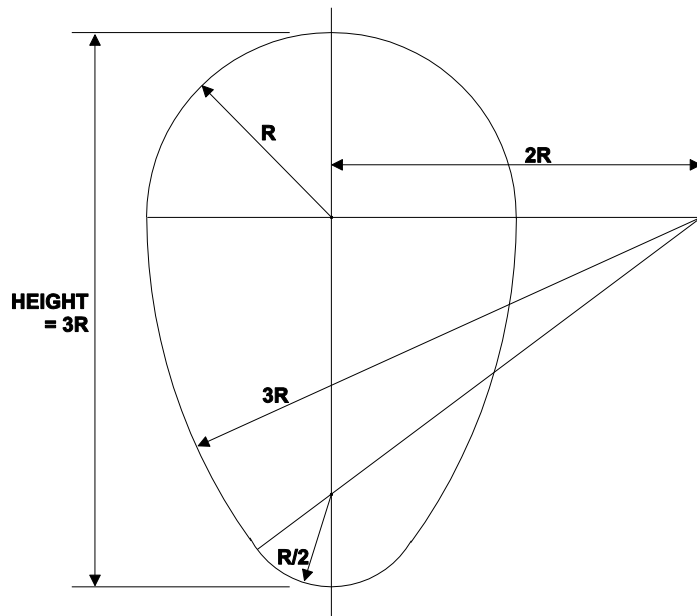

--Custom Channel----	
Type	Custom
Reset Data	No
Max Height	0.75 ft
Division	0.05 ft
Increment #	0
Width	0.000 ft
Level	0.000 ft

CUSTOM CHANNELS

- Reset Data** Old data MUST be removed before entering data for a new channel. Press **➡** then press **⬆** to Yes and press **✓** to clear old data.
- Max Height** Enter the maximum height of the channel.
- Division** Divide the maximum height into equal increments (maximum of 40) and enter this division value (example 1", 1 cm etc.)
- Increment #** Enter the increment number if you want to edit a previous entry or to skip entering widths for some levels (Note: The custom channel will interpolate widths between entry points).
- Width** Enter the measured width of the channel at the level shown (Note: To enter 0 width you must press **➡** and then **✓** to store a 0 width data point).
- Level** Displays the level of the channel for each increment and width entry.

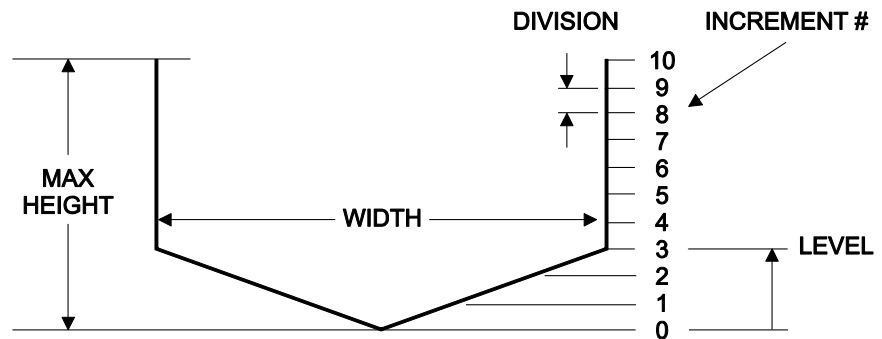

Note:

Custom channel data in equal width increments with variable height measurements must be converted to the format shown above using the "Channel Data Translator" PC software.



```

--Relay Parameters--
▶Relay           1
Function         Flow
On               1000 USG
Off              0.000 USG
  
```

RELAY PARAMETERS

Relay Press **➡** and **⬇** or **⬆** to select a relay (2 relays are standard, 4 additional are optional).

Function Press **⬇** or **⬆** to select Off, Pulse, Flow, Velocity or Level.

Pulse Set digits to the flow volume per relay pulse. Use this feature for remote samplers, chlorinators or totalizers. Minimum time between pulses is 2.25 seconds and pulse duration is 350 milliseconds.

Flow

- On Position the cursor under the numerals and press **⬇** or **⬆** to set digits to the relay On set point.
- Off Set digits to the Off set point.

Velocity

- On Position the cursor under the numerals and press **⬇** or **⬆** to set digits to the relay On set point.
- Off Set digits to the Off set point.

Level

- On Position the cursor under the numerals and press **⬇** or **⬆** to set digits to the relay On set point.
- Off Set digits to the Off set point.

LOE Mode Specify the state of the relay for loss of echo condition: Off, On or Hold.

Press **✓** to return to Menu Selections



```

-- Data Logging-----
▶Log Site ID      0
Mode              Flow
File Format       .LG2
Date             May 18/2018
Time             11:27:40
Interval         10sec
                 60min
                 30min
                 15min
                 10min
                 5min
                 2min
                 1min
                 30sec
Data Log         Stop
                 Start
                 Delete
  
```

DATA LOGGING

Press **↓** or **↑** to position cursor at Data Logging, and **→** to enter. Use **↓** or **↑** to position cursor before each menu item and **→** to enter. When settings are completed press **✓** to store and **✓** again to return to the Main Menu.

Log Site ID Enter a number from 00 to 99. The site ID will become part of the downloaded file name to help distinguish downloads from different instruments. Press **✓** to store the setting.

File Format Choose .LG2 to download data in .lg2 format for viewing on Micronics Logger software. Choose .CSV to download data in .csv format for import directly to Excel. This menu option can be changed at any time without adversely affecting existing data.

Date Press **→**, and **↑** or **↓** to scroll and select Month, Day and Year. Press **✓** to store the setting.

Time Press **→**, and **↑** or **↓** to select the current time in Hours, Minutes and Seconds. Press **✓** to store the setting.

Interval Press **↑** or **↓** to select the logging interval. Press **✓** to store the setting. Micronics recommends choosing an interval which will give you as much resolution as required and no more. Choosing too often of an interval for what is required will result in larger data files, which may take a long time to download to USB. Reference page 15 for specific download times. In critical installations, data should be downloaded often.

Data Log Stop, Start or Delete the log file. Press **↑** or **↓** to select Delete and **✓** to delete the log file. Press **↑** or **↓** to select Start and **✓** to start the logger.

Important Note: You MUST Delete an old log and Start a new log AFTER having made changes to Log Site ID, Mode, Date, Time and/or Interval for those changes to be applied.

Important Note: Changing any of the parameters in the Units/Mode menu will start a new log. It is recommended that you Delete and start a new log after changing any Units/Mode settings.

View 24-hr formatted Reports on the UF AV5500 display. Press **←** from the main display to view a formatted flow report from instruments with a built-in data logger. Press **←** to pan through Level, Velocity and Flow summaries. Press **↓** to scroll down one day or repeatedly to scroll to a specific date. Up to 365 days can be stored. Newest date will overwrite the oldest. Press **✓** to return to the main display.

RETRIEVING LOG FILE

Plug a USB Flash Memory Drive (one is included with the UF AV5500) into the USB output port on the Panel of the meter. The instrument display will show the data download icon until the log file is transferred to the memory card. The USB flash drive may be removed when the icon for download successful appears.

Download file names will appear in this format:

AVFM_ _00A.LG2
↑ ↑ ↑
MODEL TAG DOWNLOAD

Tag is set according to the Log Site ID entered in the instrument Data Logging menu.

Download letter will be A for the first download from an instrument. B for the second, then C etc. At the letter Z a - character will appear indicating that the maximum number of downloads for that instrument are on the USB flash drive. Older files can be erased or moved from the flash memory drive or a new memory drive can be used.

Note: Downloading files in .lg2 format will take approximately 35 seconds per 1% of internal log memory used.
Downloading files in .csv format will take approximately 8 minutes per 1% of internal log memory used.

OPENING .LG2 FILES

Install Micronics Logger on your PC or laptop. Select File/Open/Instrument Log (.log) to open the log file from your USB flash drive (not supplied by Micronics). Data can also be converted to .CSV via Micronics Logger software.

OPENING .CSV FILES

Use a datasheet program such as Microsoft Excel® to import data in a comma delimited format. Use Excel to manipulate or graph data.

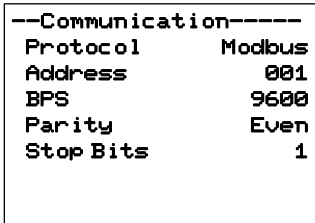

COMMUNICATION (Optional)

Press **↓** or **↑** to position cursor at Communication, and **➡** to enter. Use **↓** or **↑** to position cursor before each menu item and **➡** to enter. When settings are completed press **✓** to store and **✓** again to return to the Main Menu.

MODBUS Protocol Information:

- Transceiver: 2-wire, half-duplex
- Data format: 8 Data Bits
- Floating Point Byte Order: ABCD
- Termination: Jumper JP1 selectable 120Ω resistor. TB1 & TB2 = OFF, TB2 & TB3 = ON
- Biasing: None

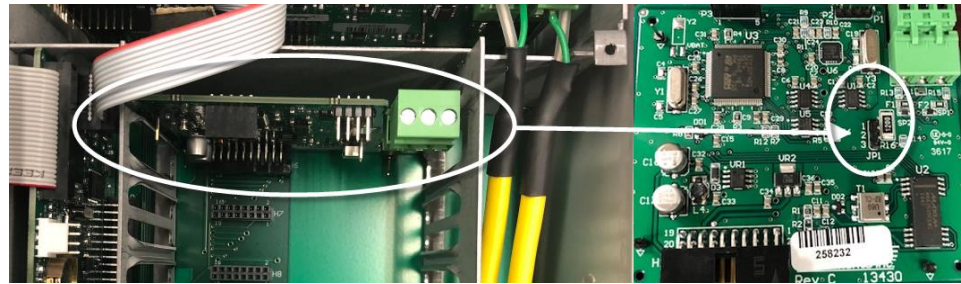

- Protocol Choose MODBUS.
- Address Device address for the UF AV5500. Valid range: 001-247 (Default: 001). This number should be unique across the bus. Press **↑** or **↓** to scroll, **➡** to select digits, and press **✓** to store the setting.
- BPS Baud rate for the MODBUS communications. Press **↑** or **↓** to select, and **✓** to store the setting. Options: 4800, 9600, 19200, 38400, 57600, 76800, and 115200 (Default: 9600).
- Parity Error checking parity for the MODBUS communications. Press **↑** or **↓** to select, and **✓** to store the setting. Options: None, Even, and Odd (Default: Even).
- Stop Bits Press **↑** or **↓** to select, and **✓** to store the setting. Options: 1 or 2 (Default: 1).



SPECIAL FUNCTIONS

-- Special Functions--	
▶Language	English
Analog Out	4-20mA
Backlight	High
Reset Totalizer	NO
Neg. Totals	NO
Rev. Flow	Off
Capture Par	No
Capture WF	No
Restore Defaults	NO
New Password	0000

Language	Select English, Spanish or French
Analog Out	Select 4-20mA or 0-5V mode for the analog output.
Backlight	Select High, Medium or Low for continuous backlight. Select Key Hi/Lo for high backlight (for 1 minute) after a keypress and then Lo backlight until a key is pressed again. Select Key High, Med or Low for backlight after a keypress and then backlight off until a key is pressed again.
Reset Totalizer	Select Yes to erase and restart the totalizer at zero. This only effects the main totalizer. The 365 day data remains unchanged.
Neg. Totals	Select Yes to have reverse flow readings deducted from the totalizer. Select No to totalize forward flow only and ignore reverse flow.
Rev Flow	Select On to enable flow direction measurement. Select Off to disable flow direction measurement so that flow in either direction is displayed and output as positive values. Select Invert to invert the sense of the flow measurement.
Capture WF	This function should only be used when instructed by a Micronics representative to do so. The function captures the ultrasonic signal so that it can be evaluated by Micronics.
Capture Par	This function captures the programming parameters in the meter. Select Yes, wait for Done to appear, then insert a USB drive into the USB port to transfer the parameters.
Restore Defaults	Select Yes to erase all user settings and return the instrument to factory default settings.
New Password	Select any number from 0000 to 9999 and press ✓. Default setting of 0000 will allow direct access to the calibration menus. Setting of any password greater than 0000 will require the password to be entered to access



the calibration menus.

Press ✓ to return to Menu Selections.

```
--Simulation-----
▶Test      Actual
Level     0.00in
Velocity  10ft/s
Flow     1982.88USG/m
4-20mA Level  20.00
4-20mA Velocity 20.00
4-20mA Flow   20.00
Relays 1 2
```

SIMULATION

Exercises the 4-20mA (0-5V) outputs, digital display and control relays.

Test Select **Maximum** and press ✓ to simulate maximum Flow, Level and Velocity and to output 20mA (5V) to the analog channels.

Select **Minimum** and press ✓ to simulate minimum Flow, Level and Velocity and to output 4mA (0V) to the analog channels.

To simulate an intermediate Flow, Level and Velocity set **Test** to **Actual** and then enter a value for the **Level** and **Velocity**. The Flow calculation, analog outputs and control relays will respond to the simulated values.

INSTALLATION – SENSOR LOCATION

For the most accurate flow measurement possible, careful consideration should be made to the placement of the sensor in relation to flow disturbances. In general, the best accuracy will occur where flow is evenly distributed across the channel/pipe and free of turbulence.

Specific installation considerations are listed and discussed in more detail below.

1. Open Discharges or Pipe/Channel Outfalls

When the QZ02 sensor is to be mounted in front (upstream) of an open discharge or pipe/channel outfall, the sensor should be placed at least 5 times the maximum head level in front of the outfall:

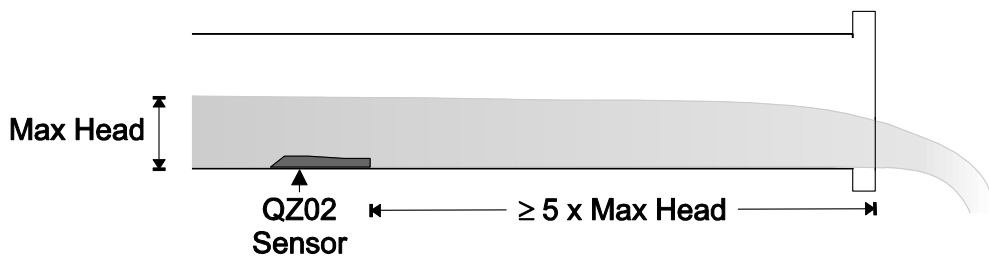

Pipe / Channel Side View

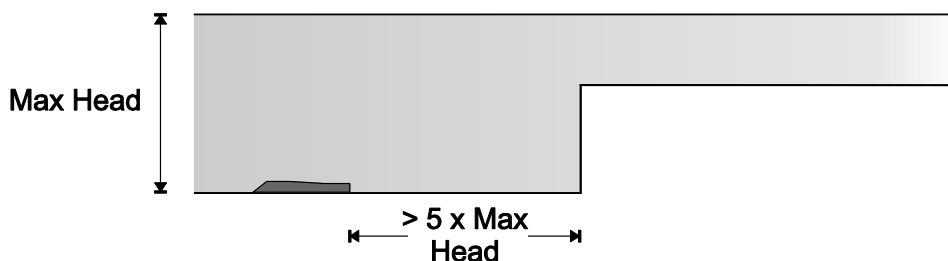
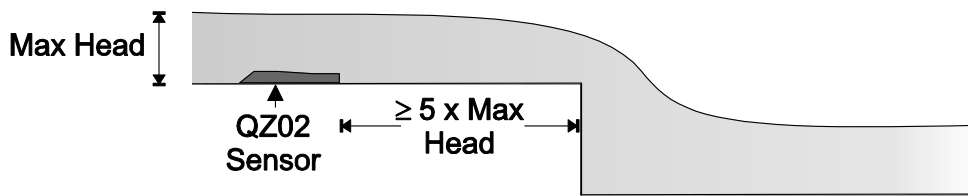

2. Hydraulic Dams

When the QZ02 sensor is to be mounted in front (upstream) of a hydraulic dam, or a Micronics VD pipe dam, the sensor should be placed at least 20 inches in front of the dam:

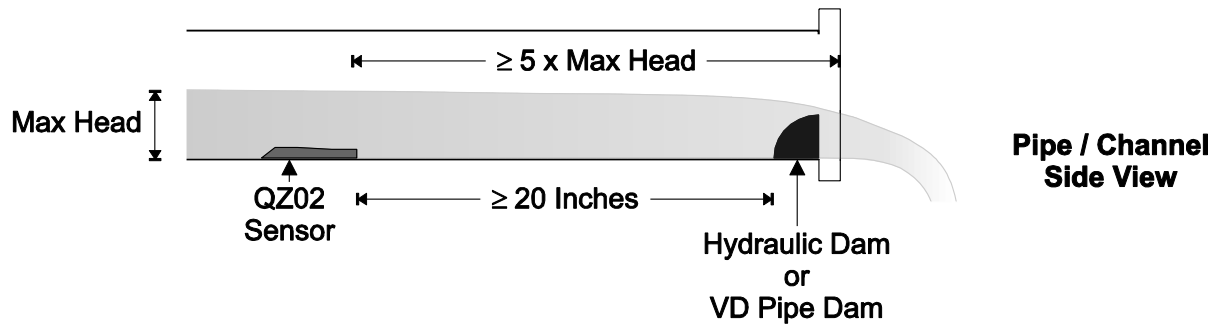

3. Pipe Grade

The pipe/channel in which the QZ02 sensor is mounted should not have a grade exceeding 3%:

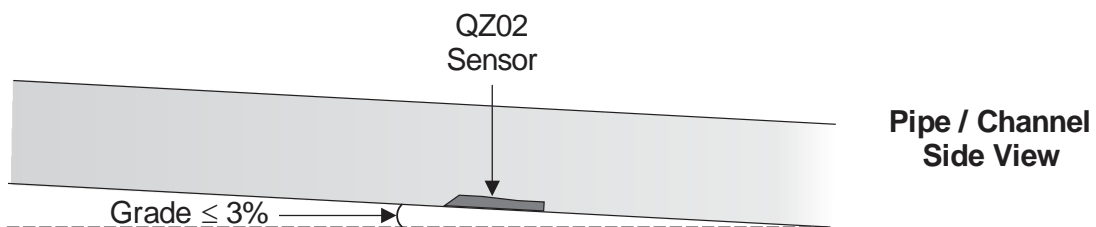

1. Flow Profile Distortion

The pipe/channel in which the QZ02 sensor is mounted should be free of bends, tees, sudden changes in slope, and there should not be objects in the pipe/channel which disturb the flow profile in front of the sensor.

In general, the QZ02 sensor should be mounted with at least 10 pipe diameters or channel widths of straight-run upstream, and 5 pipe diameters or channel widths downstream:

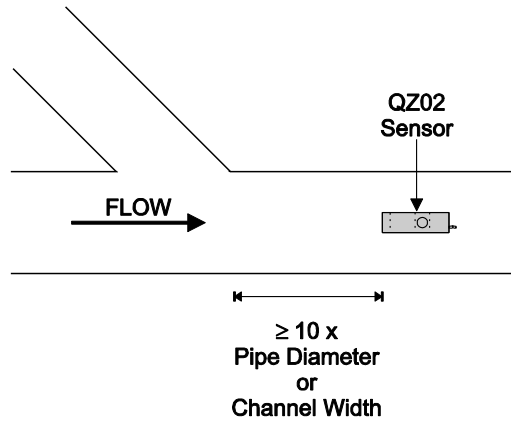

**Top-Down
View
of
Channel
or
Pipe**

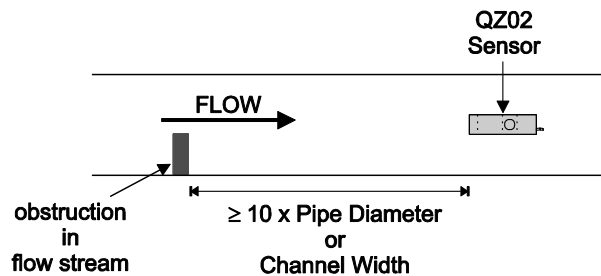
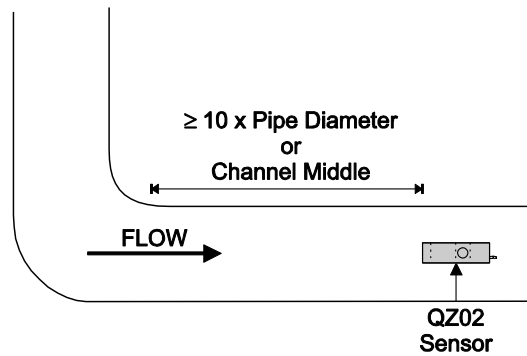

QZ02L VELOCITY-LEVEL SENSOR MOUNTING

Mount the QZ02L sensor with the stainless steel bracket and hardware supplied. Ensure that the sensor is parallel to the water surface (check with a level). Mount with the tapered end of the sensor pointing upstream and the sensor cable pointing downstream.

Clip or tie wrap the sensor cable securely to the pipe or channel wall.

Note: The mounting bracket is designed to release the sensor if weeds or rags are caught by the sensor.

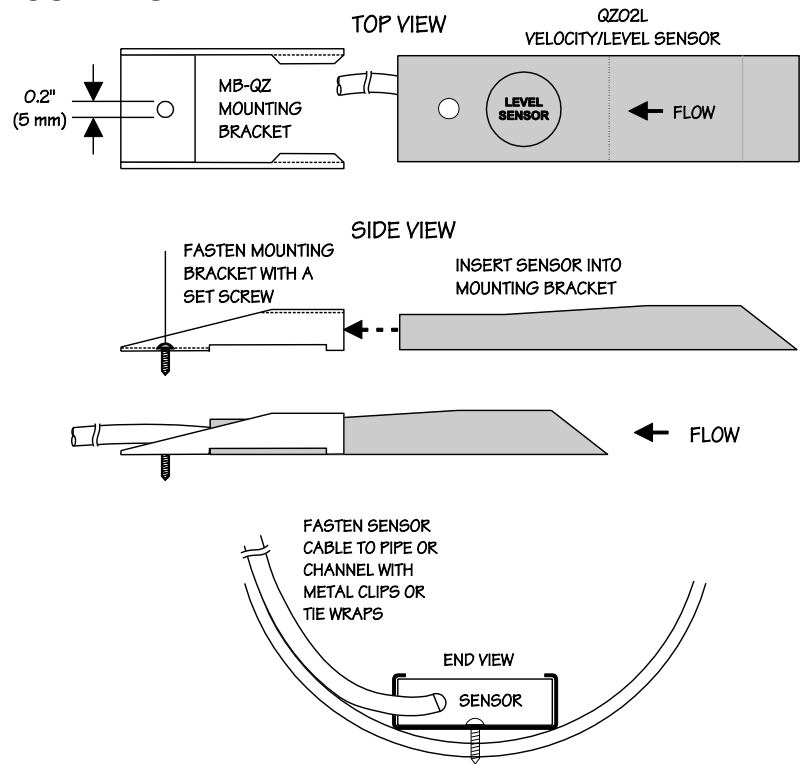

GOOD

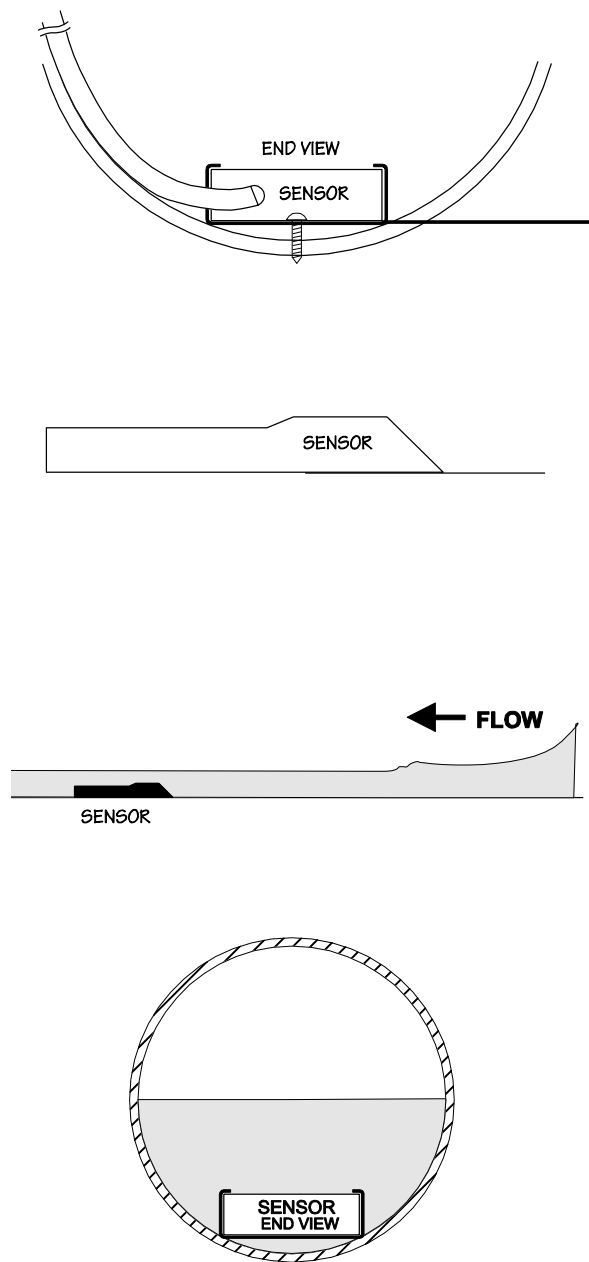

BAD

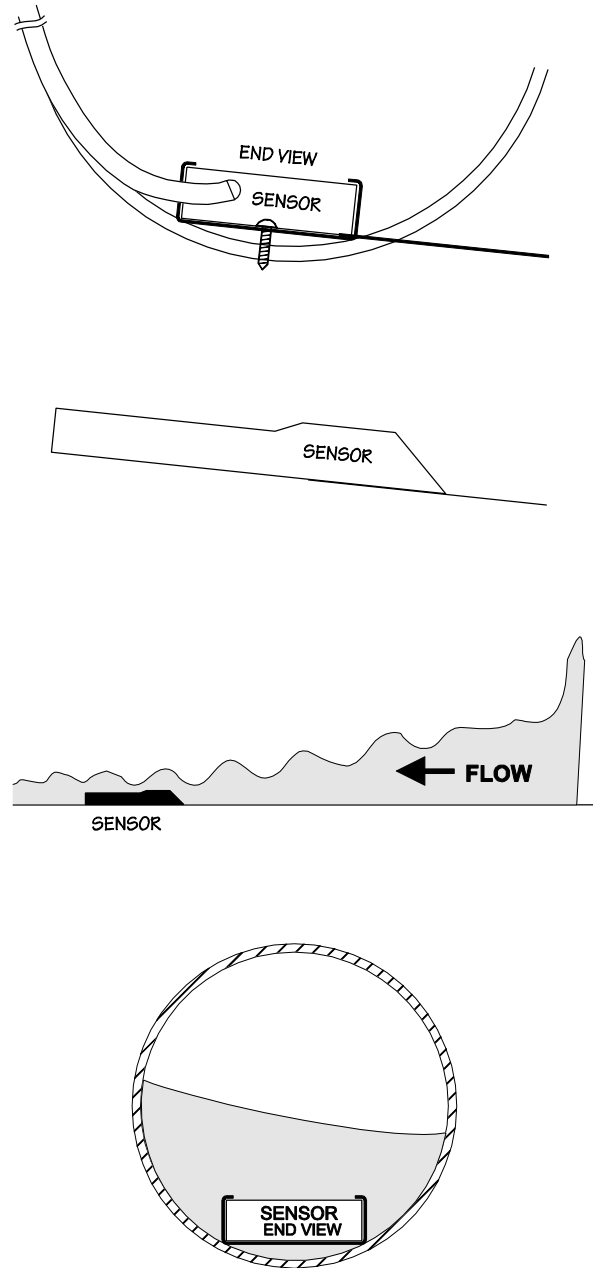

OPTIONAL PIPE BAND MOUNTING WITH QZ02L SENSOR

Install the stainless steel pipe band with the sensor mounting bracket at the invert (bottom) of the pipe. Ensure that the sensor bracket is parallel to the water surface (check with a level). Mount so the tapered end of the sensor will point upstream and the sensor cable will point downstream. (Turn the 1/4" adjustment nut clockwise to expand the bracket and secure to the pipe wall by friction fit.)

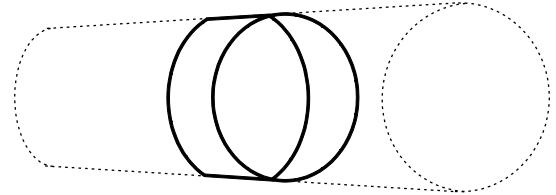

Insert the sensor into the mounting bracket and tie-wrap the sensor cable securely to the pipe band using the holes provided.

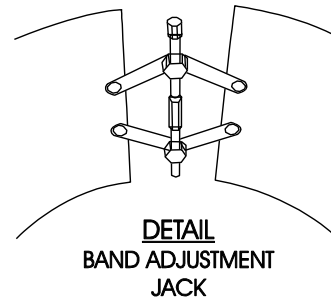
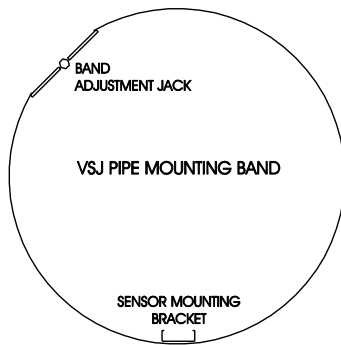

OPTIONAL QZ02L-B VELOCITY SENSOR MOUNTING

Mount the velocity sensor at or near the bottom of the channel or pipe in a position where it will be continuously submerged. The QZ02L-B velocity sensor does not have to be parallel to the water surface. Position where silt or solids will not build-up on the sensor.

OPTIONAL PZ15-LP LEVEL SENSOR MOUNTING

Mount the PZ15-LP non-contacting ultrasonic level sensor in an unobstructed position at least 8" (203.2 mm) above the high water level. Install the stainless steel mounting bracket in a horizontal position (check with a level) and then insert the PZ15-LP sensor.

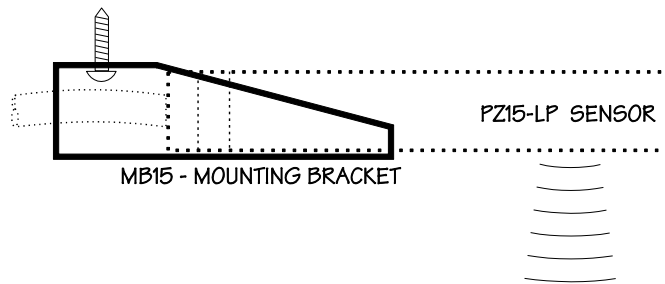

PZ15-LP MANHOLE MOUNTING

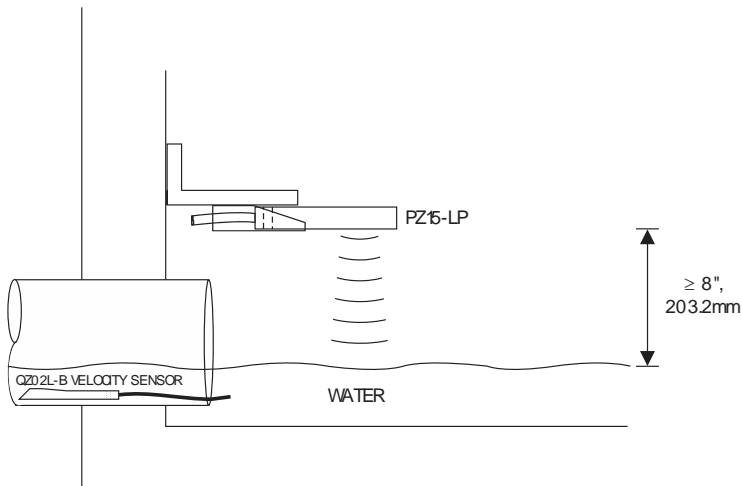

PZ15-LP PIPE MOUNTING

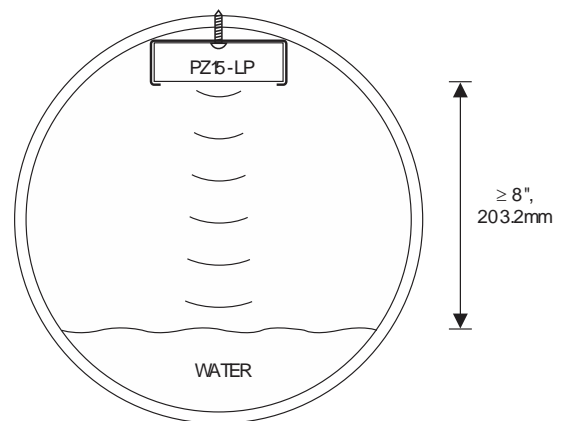

ENCLOSURE INSTALLATION

Locate the enclosure within 20 ft (6 m) of the sensor (up to 500 ft -150 m optional). The enclosure can be wall mounted with the four mounting screws (included) or panel mounted with Option PM Panel Mount kit from Micronics.

Avoid mounting the enclosure in direct sunlight to protect the electronics from damage due to overheating and condensate. In high humidity atmospheres, or where temperatures fall below freezing, Option TH Enclosure Heater and Thermostat is recommended. Seal conduit entries to prevent moisture from entering enclosure.

NEMA4X (IP66) WITH CLEAR COVER

1. Open hinged enclosure cover.
2. Insert #12 screws (supplied) through the four enclosure mounting holes to secure the enclosure to the wall or mounting stand.

Additional conduit holes can be cut in the bottom of the enclosure with a hole saw or Greenlee-type hole cutter.

DO NOT make conduit/wiring entries into the top of the enclosure.

Note: This non-metallic enclosure does not automatically provide grounding between conduit connections. Grounding must be provided as part of the installation. Ground in accordance with the requirements of the National Electrical Code. System grounding is provided by connecting grounding wires from all conduit entries to the steel mounting plate or another point which provides continuity.

CLEANING

Cleaning of the electronics is not required as a part of normal maintenance.

The submersible QZ02L sensor may need to be cleaned in applications with dirty water, or those with a lot of debris. Use 1 part household bleach to 20 parts water to clean the sensor. Immerse for 5 hours and then rinse and dry.

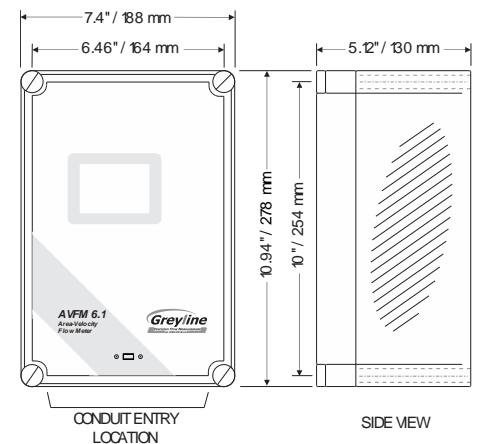
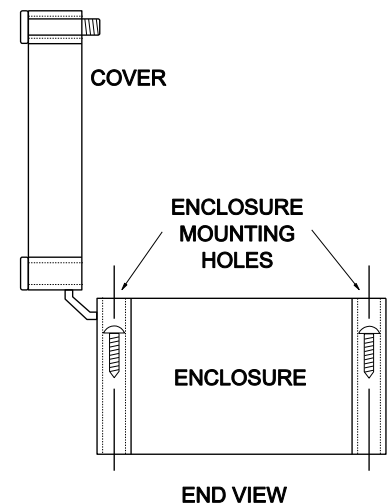



FIELD TROUBLESHOOTING

The UF AV5500 uses an ultrasonic level sensor to determine flow area and an ultrasonic Doppler sensor to measure flow velocity.

The QZ02L sensor combines both sensors in one housing.

An optional configuration uses the PZ15-LP “down-looking” level sensor and a QZ02L-B velocity sensor.

To troubleshoot the UF AV5500, verify correct operation of level and velocity measurements separately.

Note: Selecting “Restore Defaults” in the SPECIAL FUNCTION menu will return the instrument to “as-shipped” factory settings.

LEVEL (QZ02L SENSOR)

SYMPTOMS

EC percent at zero

FAULTS

- very turbulent flow
- very aerated flow
- sensor not level
- sediment/dirt/grease build-up on sensor

SOLUTIONS

- relocate sensor or use PZ15-LP
- level sensor with “Bullseye” level
- clean sensor with liquid soap

Level Inaccurate

- sensor not mounted at bottom of pipe/channel

- set a “Lvl Offset” in Calibration menu

VELOCITY (QZ02L SENSOR)

SYMPTOMS

- No velocity reading

FAULTS

- grease/sediment on sensor
- improper hook-up
- not enough suspended solids or aeration in water.
- water too clean for Doppler

SOLUTIONS

- clean sensor with detergent
- check sensor connections
- drop Alka-Seltzer tab into flow stream to create bubbles to verify lack of air in pipe.
- perform bucket test to prove Doppler works.

- Velocity reading too High/Low

- poor velocity profile in channel/pipe
- Cal Constant changed

- release sensor per suggestions in sensor location section
- change Cal Constant in Calibration menu

SENSOR CABLE RESISTANCE TEST

Unplug the 4-pin green sensor terminal from the Doppler board and connect the sensor wires as shown. With a multimeter, perform resistance checks for each set of wires. One single loose terminal may cause false readings.

Test across shield and core of each wire: TMTR (black/white) and RCVR (black). Resistance should be approximately 82.5K ohms for any cable length. High readings indicate an open circuit and low readings indicate a short or partial short in the sensor cable.

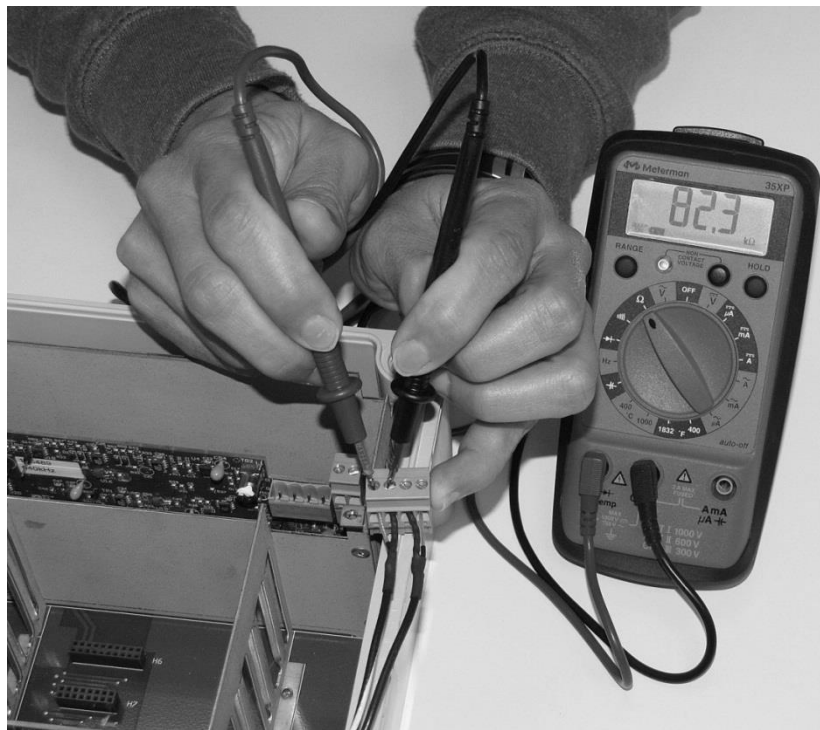

Unplug the 2-pin green sensor terminal from the level board and connect the multimeter to the pins. Resistance should be approximately 10K Ohms for any cable length. High readings indicate an open circuit and low readings indicate a short or partial short.

Resistance measured across these 2 wires also indicates fluid temperature for QZ02L sensor, or ambient temperature for PZ15-LP sensor.

Resistance vs. Temperature

Values are in Ohms

Temp °C	+0	+1	+2	+3	+4	+5	+6	+7	+8	+9
0	10000.0	10039.0772	10078.1429	10117.1970	10156.2396	10195.2706	10234.2901	10273.2980	10312.2944	10351.2792
10	10390.2525	10429.2142	10468.1644	10507.1030	10546.0301	10584.9456	10623.8496	10662.7420	10701.6229	10740.4922
20	10779.3500	10818.1962	10857.0309	10895.8540	10934.6656	10973.4656	11012.2541	11051.0310	11089.7964	11128.5502
30	11167.2925	11206.0232	11244.7424	11283.4500	11322.1461	11360.8306	11399.5036	11438.1650	11476.8149	11515.4532
40	11554.0800	11592.6952	11631.2989	11669.8910	11708.4716	11747.0406	11785.5981	11824.1440	11862.6784	11901.2012
50	11939.7125									

© 2009 Minco, All Rights Reserved

Values are in Ohms

Temp °F	+0	+1	+2	+3	+4	+5	+6	+7	+8	+9
30			10000.0	10021.7110	10043.4184	10065.1223	10086.8226	10108.5193	10130.2125	10151.9021
40	10173.5881	10195.2706	10216.9495	10238.6249	10260.2967	10281.9649	10303.6295	10325.2906	10346.9481	10368.6021
50	10390.2525	10411.8993	10433.5426	10455.1823	10476.8184	10498.4510	10520.0800	10541.7054	10563.3273	10584.9456
60	10606.5604	10628.1716	10649.7792	10671.3832	10692.9837	10714.5806	10736.1740	10757.7638	10779.3500	10800.9327
70	10822.5118	10844.0873	10865.6593	10887.2277	10908.7925	10930.3538	10951.9115	10973.4656	10995.0162	11016.5632
80	11038.1067	11059.6466	11081.1829	11102.7156	11124.2448	11145.7704	11167.2925	11188.8110	11210.3259	11231.8373
90	11253.3451	11274.8493	11296.3500	11317.8471	11339.3406	11360.8306	11382.3170	11403.7999	11425.2792	11446.7549
100	11468.2270	11489.6956	11511.1606	11532.6221	11554.0800	11575.5343	11596.9851	11618.4323	11639.8759	11661.3160
110	11682.7525	11704.1854	11725.6148	11747.0406	11768.4629	11789.8816	11811.2967	11832.7082	11854.1162	11875.5206
120	11896.9215	11918.3188	11939.7125							

© 2009 Minco, All Rights Reserved



APPLICATIONS HOTLINE

For applications assistance, advice or information on any Micronics Limited contact your Sales Representative, write to Micronics or phone the Applications Hotline below:

Tel: +44 (0) 1628 810456
Email: sales@micronicsltd.co.uk
Web Site: www.micronicsflowmeters.com

Micronics Limited
Knaves Beech Business Centre
Davies Way, Loudwater
High Wycombe, Buckinghamshire
United Kingdom, HP10 9QR

PRODUCT RETURN PROCEDURE

Instruments may be returned to Micronics for service or warranty repair.

1 Obtain an RMA Number from Micronics -

Before shipping a product to the factory please contact Micronics by telephone or email to obtain an RMA number (Returned Merchandise Authorization). This ensures fast service and correct billing or credit.

When you contact Micronics please have the following information available:

1. Model number
2. Serial number
3. Date of Purchase
4. Reason for return (description of fault or modification required)
5. Your name, company name, address and phone number

2 Clean the Sensor/Product -

Important: unclean products will not be serviced and will be returned to the sender at their expense.

1. Rinse sensor and cable to remove debris.
2. If the sensor has been exposed to sewage, immerse both sensor and cable in a solution of 1 part household bleach (Javex, Clorox etc.) to 20 parts water for 5 minutes. Important: do not immerse open end of sensor cable.
3. Dry with paper towels and pack sensor and cable in a sealed plastic bag.
4. Wipe the outside of the enclosure to remove dirt or deposits.
5. Return to Micronics for service.

LIMITED WARRANTY

Micronics Limited warrants, to the original purchaser, its products to be free from defects in material and workmanship for a period of one year from date of invoice. Micronics will replace or repair, free of charge, any Micronics product if it has been proven to be defective within the warranty period. This warranty does not cover any expenses incurred in the removal and re-installation of the product.

If a product manufactured by Micronics should prove defective within the first year, return it freight prepaid to Micronics Limited along with a copy of your invoice.

This warranty does not cover damages due to improper installation or handling, acts of nature, or unauthorized service. Modifications to or tampering with any part shall void this warranty. This warranty does not cover any equipment used in connection with the product or consequential damages due to a defect in the product.

All implied warranties are limited to the duration of this warranty. This is the complete warranty by Micronics and no other warranty is valid against Micronics. Some states do not allow limitations on how long an implied warranty lasts or limitation of incidental or consequential damages, so the above limitations or exclusions may not apply to you.

This warranty gives you specific legal rights, and you may also have other rights which vary from state to state.

Micronics Limited.

APPENDIX A – OPTIONS

EXTRA SENSOR CABLE (OPTION VXC)

Each Micronics UF AV5500 flow meter includes 25 ft. (7.6 m), 50 ft. (15 m) or 100 ft. (30 m) tri-coaxial sensor cable. This cable is shielded from electrical interference and is watertight with a polyurethane jacket. Additional cable and Cable Junction Box (Option JB2X or JB4X) may be ordered with the flow meter, or the cable may be spliced and extended up to 500 ft (152 m) total length as required during installation. No adjustment is required when the sensor cable is extended or shortened. Use only Micronics tri-coaxial VXC shielded cable, or run three RG174U coaxial cables in a metal conduit.

Extended sensor cable should be installed in rigid metal conduit for mechanical and electrical noise protection. Recommended installation with a junction box is illustrated below:

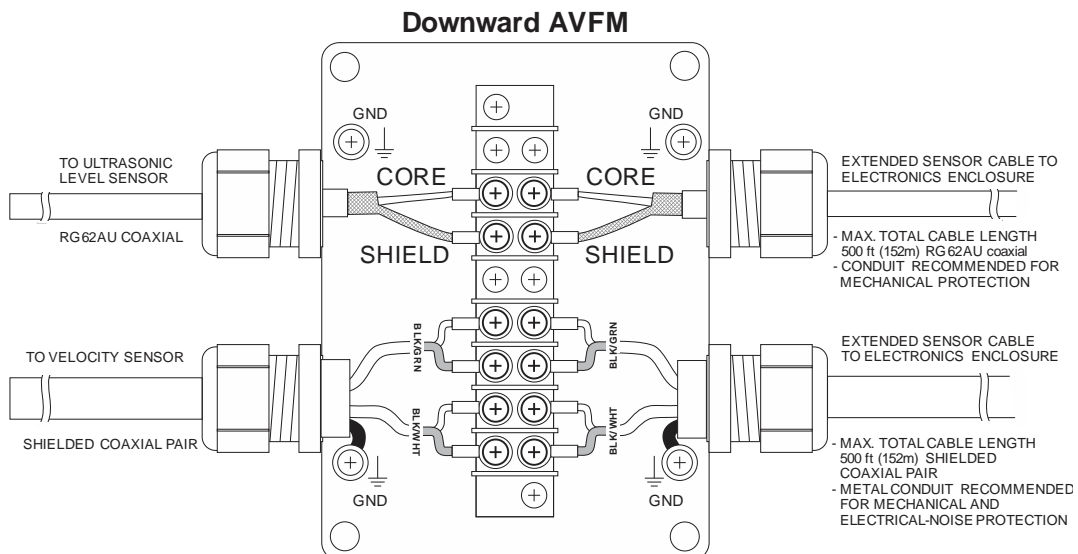
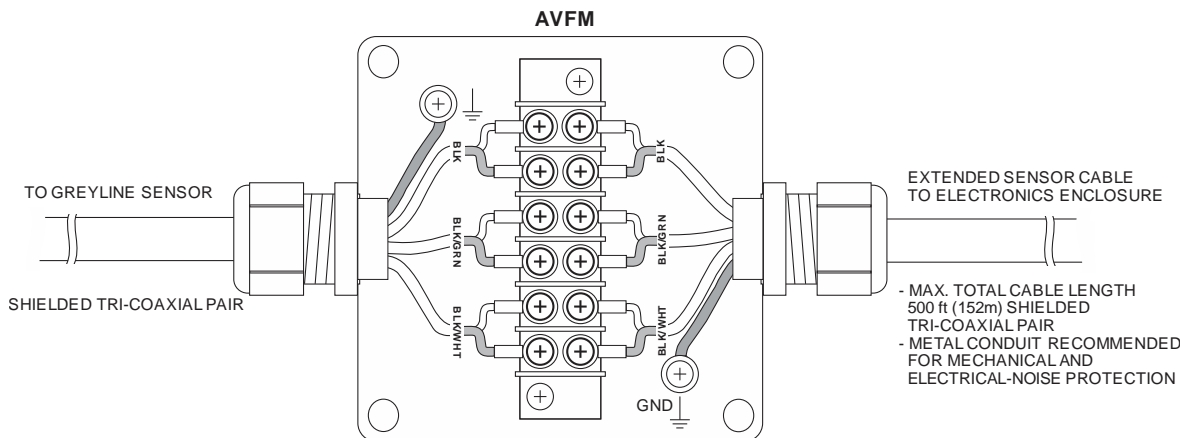

COAXIAL CABLE PREPARATION

VXC UF AV5500 sensor cable can be cut and spliced up to a maximum length of 500 ft (152 m). Cable ends must be prepared as illustrated below.

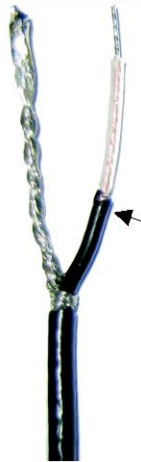

GOOD

BLACK
(CONDUCTIVE)
SLEEVE
HAS BEEN
REMOVED



BAD

BLACK
(CONDUCTIVE)
SLEEVE
HAS NOT BEEN
REMOVED

JUNCTION BOX - OPTION JB2X & JB4X

NEMA4X (IP66) polycarbonate Junction Box with terminal strips is available from Micronics Limited. Includes compression fittings for watertight coaxial cable entries.

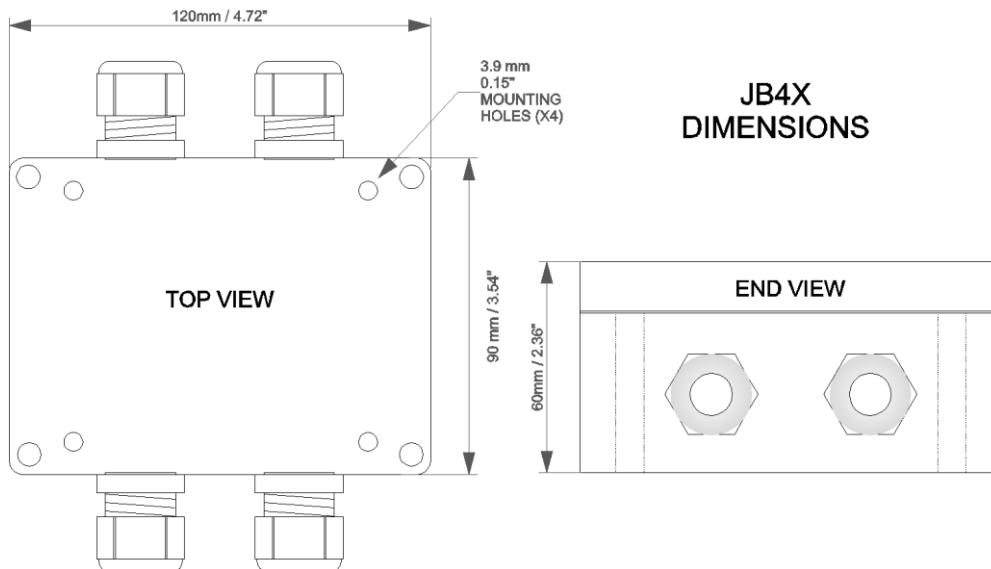
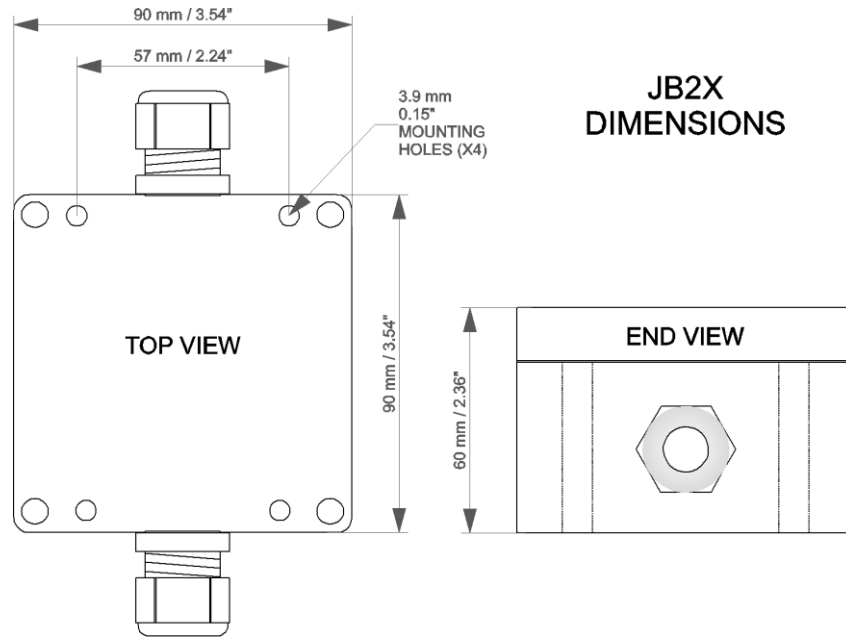

SS PIPE MOUNTING BAND – OPTION VSJ

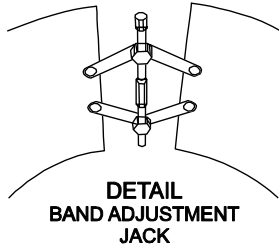

Use optional VSJ stainless steel Pipe Mounting Bands for easy Sensor installation in round pipes.

Each Pipe Band includes:

- Band Adjustment Jack allowing $\pm 0.5"$ (13 mm) adjustment from the nominal band size.
Note: VSJ6 and VSJ8 bands do not include adjustment jacks - they secure to pipe by spring tension.
- Stainless steel bracket for Sensor mounting.
- Pre-drilled for tie wraps (included) to secure Sensor cable.

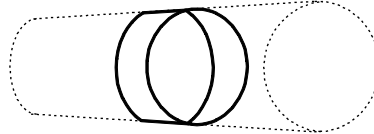
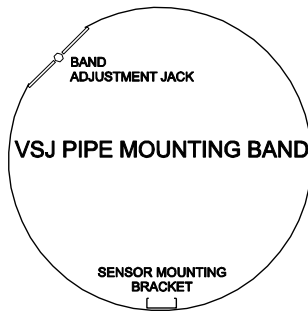

CODE BAND SIZE

VSJ6	6"/150 mm ID pipes
VSJ8	8"/200 mm ID pipes
VSJ10	10"/250 mm ID pipes
VSJ12	12"/300 mm ID pipes
VSJ14	14"/350 mm ID pipes
VSJ15	15"/375 mm ID pipes
VSJ16	16"/400 mm ID pipes
VSJ18	18"/450 mm ID pipes
VSJ20	20"/500 mm ID pipes
VSJ24	24"/600 mm ID pipes
VSJ30	30"/750 mm ID pipes

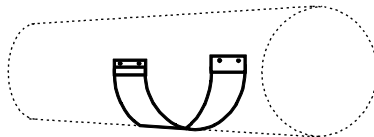
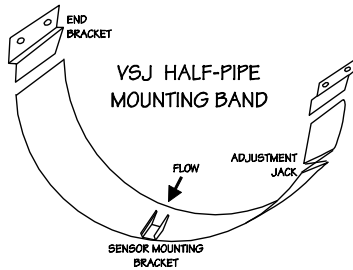

VSJ32-40	32-40" / 800-1000 mm ID pipes
VSJ42-54	42-54" / 1100-1375 mm ID pipes
VSJ56-72	56-72" / 1400-1800 mm ID pipes

Mounting Instructions:

Install the stainless steel pipe band with the sensor mounting bracket at the invert (bottom) of the pipe. Ensure that the sensor bracket is parallel to the water surface (check with a level). Mount so the tapered end of the sensor will point upstream and the sensor cable will point downstream. Turn the $\frac{1}{4}"$ hex nut clockwise to expand the bracket and secure to the pipe wall by friction fit.

Insert the sensor into the mounting bracket and clip or tie wrap the sensor cable securely to the stainless steel pipe band.

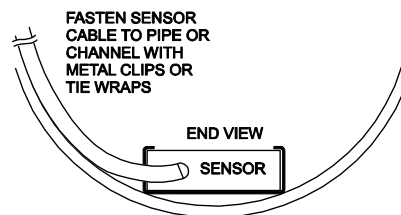



SENSOR INTRINSIC SAFETY

When connected through Intrinsic Safety Barriers, the Micronics Sensor Model QZ02L and PZ series are CSA certified for installation in a hazardous location rated:

Class I, Division 1, Groups C,D
Class II, Division 1, Groups E,F,G
Class III

Intrinsic Safety Barriers may be ordered with the Micronics instrument and are supplied mounted in the Micronics instrument enclosure. Replacement barrier fuses (Part No. ISB- 011239) may be purchased separately. The instrument enclosure containing the Intrinsic Safety Barriers must be installed in a non-hazardous location.

GN3SPEC-ISB-10

The intrinsic safety barrier assemblies installed in the AVFM 6.1 limit the voltage and current supplied to the transducers to the values listed under 'Barrier Specifications'. To safely install Greyline transducer(s) certified for use in hazardous locations you must refer to the installation drawings/specifications of the certified transducer(s).

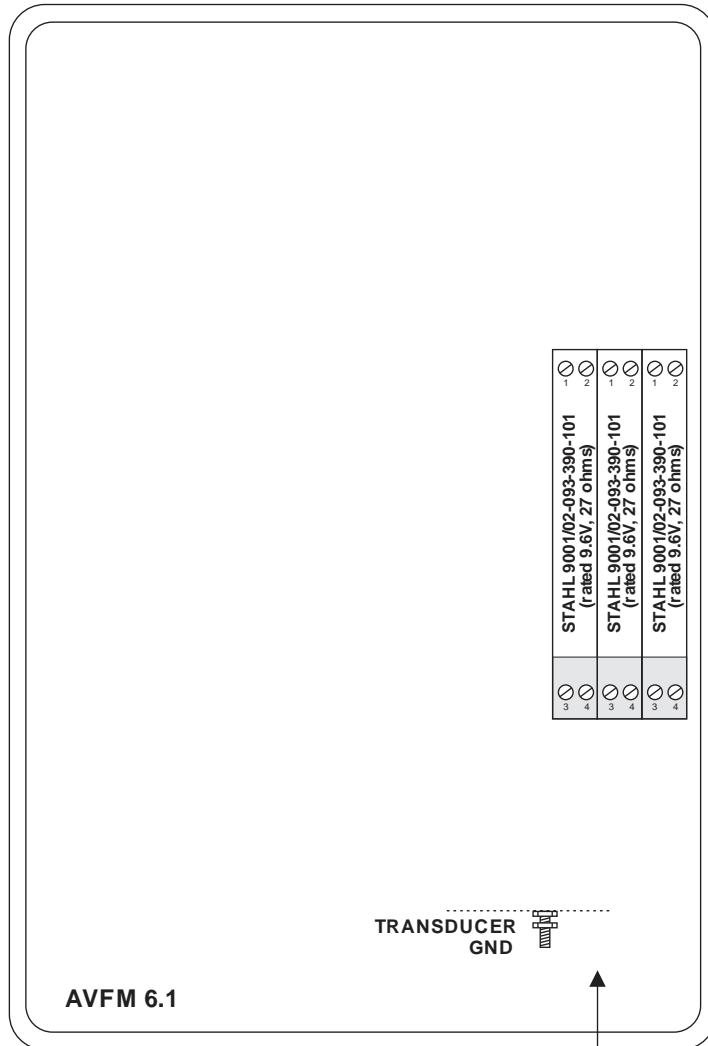

Installed in
Non-Hazardous Location

BARRIER SPECIFICATIONS

STAHL BARRIER	System Parameters	Entity Parameters					
		U_m	V_{oc}	I_{sc}	P_0	C_a	L_a
9001/02-093-390-101	9.6V, 27 ohms	250V	9.3V	390mA	906.8mW	4.1 μ F	0.16mH

MODBUS® COMMUNICATION

MODBUS® serial interface connections are made at the RS485 card's terminal block if your UF AV5500 was ordered with this card, or if one was added after installation. Card location:

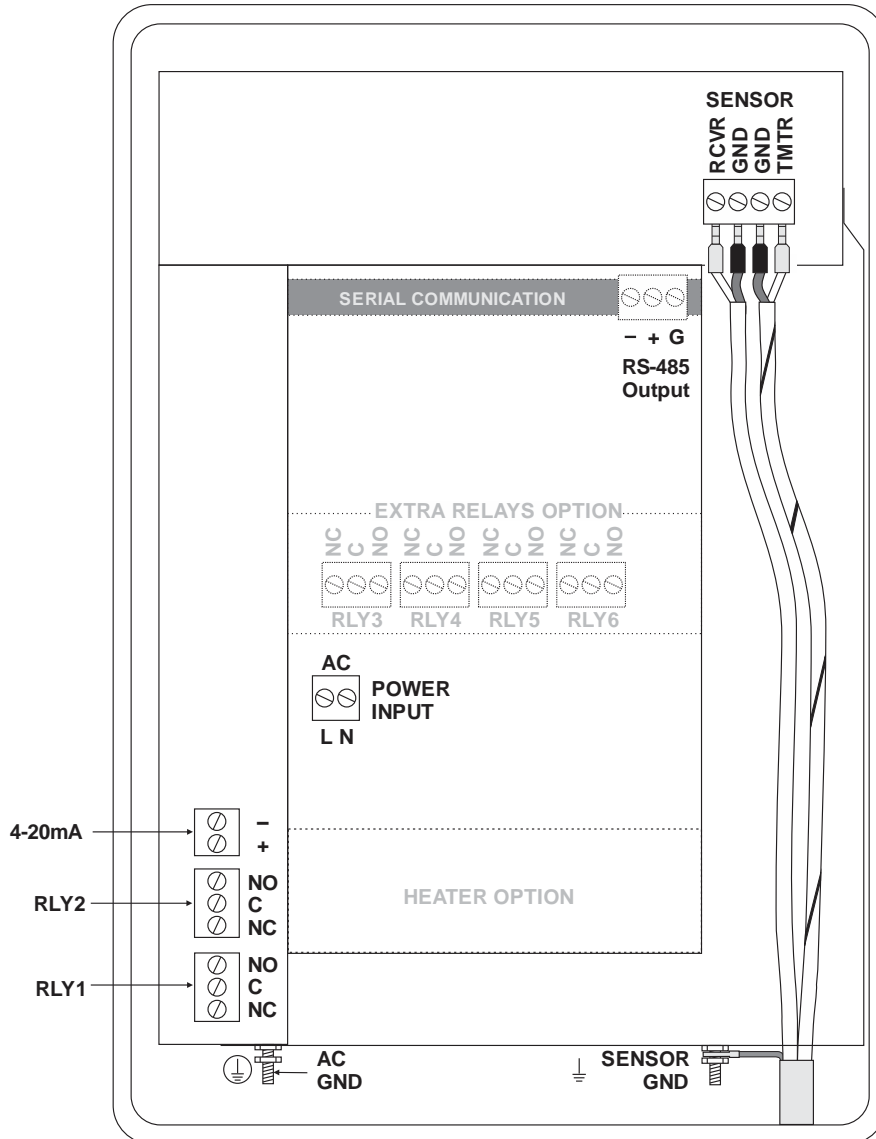

Transceiver:	2-wire, half-duplex
MODBUS Address (MAC address) range:	1-255 (Default: 001)
BAUD rates:	4800, 9600, 19200, 38400, 57600, 76800 or 115200 (Default: 9600)
Data Bits:	8
Parity:	None, Even, Odd (Default: Even)
Stop Bits:	1, 2 (Default: 1)
Termination:	120 Ohms or none (Default: None) Jumper JP1 position 1 & 2 = OFF (No term) Jumper JP1 position 2 & 3 = ON (Term)
Biasing:	None
Flow Control:	None

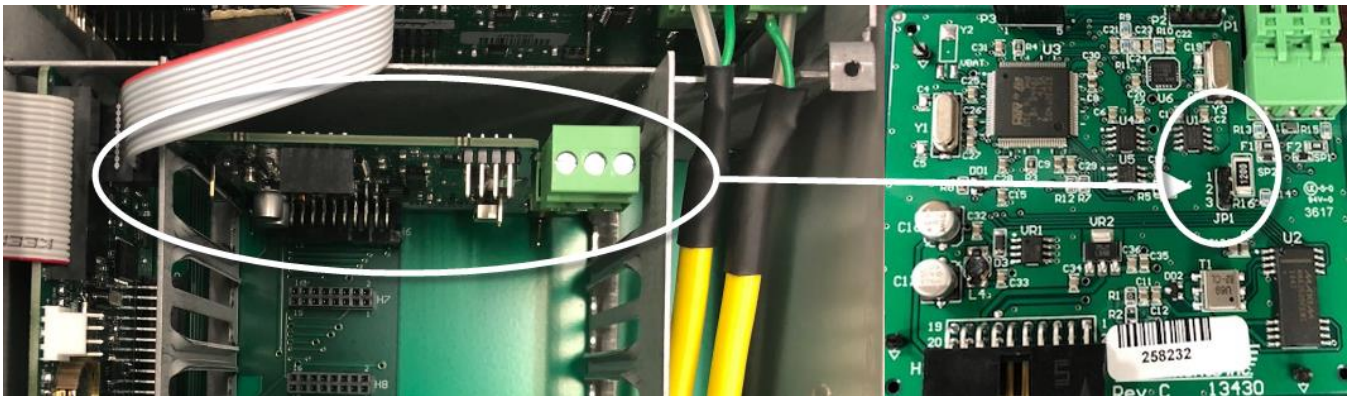

Termination Jumper Position

Function Codes Supported:
01 – Read Coil(s)
02 – Read Discreet Input(s)
04 – Read Input Register(s)
05 – Write Single Coil
06 – Write Single Register
15 – Write Multiple Coils
16 – Write Multiple Registers
17 – Report Slave ID



MODBUS® MEMORY MAP

Register Address	Description	Register Type	Data Range	Over Range	Read/Write	Comments
1	Reset Volume Total	Coil	NA	NA	Read/Write	Turn coil ON (1) to reset total on UF AV5500. Turn coil to OFF (0) once reset is complete.

Register Address	Description	Register Type	Data Range	Over Range	Read/Write	Comments
10001	Pulse Output 1 Status	Discreet Input	NA	NA	Read	(0) indicates pulse output is OFF or inactive. (1) indicates pulse output is ON or active.
10002	Pulse Output 2 Status	Discreet Input	NA	NA	Read	(0) indicates pulse output is OFF or inactive. (1) indicates pulse output is ON or active.

Register Address	Description	Register Type	Format Type	Comments
30001	Flow Velocity - ft/s	Input Register	Floating Point Register (1 of 2)	
30002	Flow Velocity - ft/s	Input Register	Floating Point Register (2 of 2)	
30003	Flow Velocity - m/s	Input Register	Floating Point Register (1 of 2)	
30004	Flow Velocity - m/s	Input Register	Floating Point Register (2 of 2)	
30101	Flow Rate - GPM (USG/min)	Input Register	Floating Point Register (1 of 2)	
30102	Flow Rate - GPM (USG/min)	Input Register	Floating Point Register (2 of 2)	
30103	Flow Rate - L/sec	Input Register	Floating Point Register (1 of 2)	
30104	Flow Rate - L/ssec	Input Register	Floating Point Register (2 of 2)	
30105	Flow Rate - ft ³ /min	Input Register	Floating Point Register (1 of 2)	
30106	Flow Rate - ft ³ /min	Input Register	Floating Point Register (2 of 2)	
30107	Flow Rate - m ³ /hr	Input Register	Floating Point Register (1 of 2)	
30108	Flow Rate - m ³ /hr	Input Register	Floating Point Register (2 of 2)	
30109	Flow Rate - USG/sec	Input Register	Floating Point Register (1 of 2)	
30110	Flow Rate - USG/sec	Input Register	Floating Point Register (2 of 2)	
30111	Flow Rate - USG/hr	Input Register	Floating Point Register (1 of 2)	
30112	Flow Rate - USG/hr	Input Register	Floating Point Register (2 of 2)	



UF AV5500 Area-Velocity Flow Meter

Register Address	Description	Register Type	Format Type	Comments
30113	Flow Rate - USG/day	Input Register	Floating Point Register (1 of 2)	
30114	Flow Rate - USG/day	Input Register	Floating Point Register (2 of 2)	
30115	Flow Rate - ft ³ /s	Input Register	Floating Point Register (1 of 2)	
30116	Flow Rate - ft ³ /s	Input Register	Floating Point Register (2 of 2)	
30117	Flow Rate - ft ³ /hr	Input Register	Floating Point Register (1 of 2)	
30118	Flow Rate - ft ³ /hr	Input Register	Floating Point Register (2 of 2)	
30119	Flow Rate - ft ³ /day	Input Register	Floating Point Register (1 of 2)	
30120	Flow Rate - ft ³ /day	Input Register	Floating Point Register (2 of 2)	
30121	Flow Rate - USMG/sec	Input Register	Floating Point Register (1 of 2)	USMG = US Million Gallons
30122	Flow Rate - USMG/sec	Input Register	Floating Point Register (2 of 2)	USMG = US Million Gallons
30123	Flow Rate - USMG/min	Input Register	Floating Point Register (1 of 2)	USMG = US Million Gallons
30124	Flow Rate - USMG/min	Input Register	Floating Point Register (2 of 2)	USMG = US Million Gallons
30125	Flow Rate - USMG/hr	Input Register	Floating Point Register (1 of 2)	USMG = US Million Gallons
30126	Flow Rate - USMG/hr	Input Register	Floating Point Register (2 of 2)	USMG = US Million Gallons
30127	Flow Rate - USMG/day	Input Register	Floating Point Register (1 of 2)	USMG = US Million Gallons
30128	Flow Rate - USMG/day	Input Register	Floating Point Register (2 of 2)	USMG = US Million Gallons
30129	Flow Rate - L/min	Input Register	Floating Point Register (1 of 2)	
30130	Flow Rate - L/min	Input Register	Floating Point Register (2 of 2)	
30131	Flow Rate - L/hr	Input Register	Floating Point Register (1 of 2)	
30132	Flow Rate - L/hr	Input Register	Floating Point Register (2 of 2)	
30133	Flow Rate - L/day	Input Register	Floating Point Register (1 of 2)	
30134	Flow Rate - L/day	Input Register	Floating Point Register (2 of 2)	
30135	Flow Rate - m ³ /sec	Input Register	Floating Point Register (1 of 2)	
30136	Flow Rate - m ³ /sec	Input Register	Floating Point Register (2 of 2)	



UF AV5500 Area-Velocity Flow Meter

Register Address	Description	Register Type	Format Type	Comments
30137	Flow Rate - m ³ /min	Input Register	Floating Point Register (1 of 2)	
30138	Flow Rate - m ³ /min	Input Register	Floating Point Register (2 of 2)	
30139	Flow Rate - m ³ /day	Input Register	Floating Point Register (1 of 2)	
30140	Flow Rate - m ³ /day	Input Register	Floating Point Register (2 of 2)	
30141	Flow Rate - IG/sec	Input Register	Floating Point Register (1 of 2)	IG = Imperial Gallons
30142	Flow Rate - IG/sec	Input Register	Floating Point Register (2 of 2)	IG = Imperial Gallons
30143	Flow Rate - IG/min	Input Register	Floating Point Register (1 of 2)	IG = Imperial Gallons
30144	Flow Rate - IG/min	Input Register	Floating Point Register (2 of 2)	IG = Imperial Gallons
30145	Flow Rate - IG/hr	Input Register	Floating Point Register (1 of 2)	IG = Imperial Gallons
30146	Flow Rate - IG/hr	Input Register	Floating Point Register (2 of 2)	IG = Imperial Gallons
30147	Flow Rate - IG/day	Input Register	Floating Point Register (1 of 2)	IG = Imperial Gallons
30148	Flow Rate - IG/day	Input Register	Floating Point Register (2 of 2)	IG = Imperial Gallons
30149	Flow Rate - IMG/sec	Input Register	Floating Point Register (1 of 2)	IMG = Imperial Million Gallons
30150	Flow Rate - IMG/sec	Input Register	Floating Point Register (2 of 2)	IMG = Imperial Million Gallons
30151	Flow Rate - IMG/min	Input Register	Floating Point Register (1 of 2)	IMG = Imperial Million Gallons
30152	Flow Rate - IMG/min	Input Register	Floating Point Register (2 of 2)	IMG = Imperial Million Gallons
30153	Flow Rate - IMG/hr	Input Register	Floating Point Register (1 of 2)	IMG = Imperial Million Gallons
30154	Flow Rate - IMG/hr	Input Register	Floating Point Register (2 of 2)	IMG = Imperial Million Gallons
30155	Flow Rate - IMG/day	Input Register	Floating Point Register (1 of 2)	IMG = Imperial Million Gallons
30156	Flow Rate - IMG/day	Input Register	Floating Point Register (2 of 2)	IMG = Imperial Million Gallons
30157	Flow Rate - bbl/sec	Input Register	Floating Point Register (1 of 2)	bbl = US Oil Barrel = 42 Gallons
30158	Flow Rate - bbl/sec	Input Register	Floating Point Register (2 of 2)	bbl = US Oil Barrel = 42 Gallons
30159	Flow Rate - bbl/min	Input Register	Floating Point Register (1 of 2)	bbl = US Oil Barrel = 42 Gallons
30160	Flow Rate - bbl/min	Input Register	Floating Point Register (2 of 2)	bbl = US Oil Barrel = 42 Gallons



UF AV5500 Area-Velocity Flow Meter

Register Address	Description	Register Type	Format Type	Comments
30161	Flow Rate - bbl/hr	Input Register	Floating Point Register (1 of 2)	bbl = US Oil Barrel = 42 Gallons
30162	Flow Rate - bbl/hr	Input Register	Floating Point Register (2 of 2)	bbl = US Oil Barrel = 42 Gallons
30163	Flow Rate - bbl/day	Input Register	Floating Point Register (1 of 2)	bbl = US Oil Barrel = 42 Gallons
30164	Flow Rate - bbl/day	Input Register	Floating Point Register (2 of 2)	bbl = US Oil Barrel = 42 Gallons
30165	Previous day Average Flow Rate - GPM (USG/min)	Input Register	Floating Point Register (1 of 2)	
30166	Previous day Average Flow Rate - GPM (USG/min)	Input Register	Floating Point Register (2 of 2)	
30167	Previous day Average Flow Rate - L/sec	Input Register	Floating Point Register (1 of 2)	
30168	Previous day Average Flow Rate - L/ssec	Input Register	Floating Point Register (2 of 2)	
30169	Previous day Average Flow Rate - ft3/min	Input Register	Floating Point Register (1 of 2)	
30170	Previous day Average Flow Rate - ft3/min	Input Register	Floating Point Register (2 of 2)	
30171	Previous day Average Flow Rate - m3/hr	Input Register	Floating Point Register (1 of 2)	
30172	Previous day Average Flow Rate - m3/hr	Input Register	Floating Point Register (2 of 2)	
30173	Previous day Average Flow Rate - USG/sec	Input Register	Floating Point Register (1 of 2)	
30174	Previous day Average Flow Rate - USG/sec	Input Register	Floating Point Register (2 of 2)	
30175	Previous day Average Flow Rate - USG/hr	Input Register	Floating Point Register (1 of 2)	
30176	Previous day Average Flow Rate - USG/hr	Input Register	Floating Point Register (2 of 2)	
30177	Previous day Average Flow Rate - USG/day	Input Register	Floating Point Register (1 of 2)	
30178	Previous day Average Flow Rate - USG/day	Input Register	Floating Point Register (2 of 2)	
30179	Previous day Average Flow Rate - ft3/s	Input Register	Floating Point Register (1 of 2)	
30180	Previous day Average Flow Rate - ft3/s	Input Register	Floating Point Register (2 of 2)	
30181	Previous day Average Flow Rate - ft3/hr	Input Register	Floating Point Register (1 of 2)	
30182	Previous day Average Flow Rate - ft3/hr	Input Register	Floating Point Register (2 of 2)	



UF AV5500 Area-Velocity Flow Meter

Register Address	Description	Register Type	Format Type	Comments
30183	Previous day Average Flow Rate - ft ³ /day	Input Register	Floating Point Register (1 of 2)	
30184	Previous day Average Flow Rate - ft ³ /day	Input Register	Floating Point Register (2 of 2)	
30185	Previous day Average Flow Rate - USMG/sec	Input Register	Floating Point Register (1 of 2)	USMG = US Million Gallons
30186	Previous day Average Flow Rate - USMG/sec	Input Register	Floating Point Register (2 of 2)	USMG = US Million Gallons
30187	Previous day Average Flow Rate - USMG/min	Input Register	Floating Point Register (1 of 2)	USMG = US Million Gallons
30188	Previous day Average Flow Rate - USMG/min	Input Register	Floating Point Register (2 of 2)	USMG = US Million Gallons
30189	Previous day Average Flow Rate - USMG/hr	Input Register	Floating Point Register (1 of 2)	USMG = US Million Gallons
30190	Previous day Average Flow Rate - USMG/hr	Input Register	Floating Point Register (2 of 2)	USMG = US Million Gallons
30191	Previous day Average Flow Rate - USMG/day	Input Register	Floating Point Register (1 of 2)	USMG = US Million Gallons
30192	Previous day Average Flow Rate - USMG/day	Input Register	Floating Point Register (2 of 2)	USMG = US Million Gallons
30193	Previous day Average Flow Rate - L/min	Input Register	Floating Point Register (1 of 2)	
30194	Previous day Average Flow Rate - L/min	Input Register	Floating Point Register (2 of 2)	
30195	Previous day Average Flow Rate - L/hr	Input Register	Floating Point Register (1 of 2)	
30196	Previous day Average Flow Rate - L/hr	Input Register	Floating Point Register (2 of 2)	
30197	Previous day Average Flow Rate - L/day	Input Register	Floating Point Register (1 of 2)	
30198	Previous day Average Flow Rate - L/day	Input Register	Floating Point Register (2 of 2)	
30199	Previous day Average Flow Rate - m ³ /sec	Input Register	Floating Point Register (1 of 2)	
30200	Previous day Average Flow Rate - m ³ /sec	Input Register	Floating Point Register (2 of 2)	
30201	Previous day Average Flow Rate - m ³ /min	Input Register	Floating Point Register (1 of 2)	
30202	Previous day Average Flow Rate - m ³ /min	Input Register	Floating Point Register (2 of 2)	
30203	Previous day Average Flow Rate - m ³ /day	Input Register	Floating Point Register (1 of 2)	
30204	Previous day Average Flow Rate - m ³ /day	Input Register	Floating Point Register (2 of 2)	
30205	Previous day Average Flow Rate - IG/sec	Input Register	Floating Point Register (1 of 2)	IG = Imperial Gallons
30206	Previous day Average Flow Rate - IG/sec	Input Register	Floating Point Register (2 of 2)	IG = Imperial Gallons



UF AV5500 Area-Velocity Flow Meter

Register Address	Description	Register Type	Format Type	Comments
30207	Previous day Average Flow Rate - IG/min	Input Register	Floating Point Register (1 of 2)	IG = Imperial Gallons
30208	Previous day Average Flow Rate - IG/min	Input Register	Floating Point Register (2 of 2)	IG = Imperial Gallons
30209	Previous day Average Flow Rate - IG/hr	Input Register	Floating Point Register (1 of 2)	IG = Imperial Gallons
30210	Previous day Average Flow Rate - IG/hr	Input Register	Floating Point Register (2 of 2)	IG = Imperial Gallons
30211	Previous day Average Flow Rate - IG/day	Input Register	Floating Point Register (1 of 2)	IG = Imperial Gallons
30212	Previous day Average Flow Rate - IG/day	Input Register	Floating Point Register (2 of 2)	IG = Imperial Gallons
30213	Previous day Average Flow Rate - IMG/sec	Input Register	Floating Point Register (1 of 2)	IMG = Imperial Million Gallons
30214	Previous day Average Flow Rate - IMG/sec	Input Register	Floating Point Register (2 of 2)	IMG = Imperial Million Gallons
30215	Previous day Average Flow Rate - IMG/min	Input Register	Floating Point Register (1 of 2)	IMG = Imperial Million Gallons
30216	Previous day Average Flow Rate - IMG/min	Input Register	Floating Point Register (2 of 2)	IMG = Imperial Million Gallons
30217	Previous day Average Flow Rate - IMG/hr	Input Register	Floating Point Register (1 of 2)	IMG = Imperial Million Gallons
30218	Previous day Average Flow Rate - IMG/hr	Input Register	Floating Point Register (2 of 2)	IMG = Imperial Million Gallons
30219	Previous day Average Flow Rate - IMG/day	Input Register	Floating Point Register (1 of 2)	IMG = Imperial Million Gallons
30220	Previous day Average Flow Rate - IMG/day	Input Register	Floating Point Register (2 of 2)	IMG = Imperial Million Gallons
30221	Previous day Average Flow Rate - bbl/sec	Input Register	Floating Point Register (1 of 2)	bbl = US Oil Barrel = 42 Gallons
30222	Previous day Average Flow Rate - bbl/sec	Input Register	Floating Point Register (2 of 2)	bbl = US Oil Barrel = 42 Gallons
30223	Previous day Average Flow Rate - bbl/min	Input Register	Floating Point Register (1 of 2)	bbl = US Oil Barrel = 42 Gallons
30224	Previous day Average Flow Rate - bbl/min	Input Register	Floating Point Register (2 of 2)	bbl = US Oil Barrel = 42 Gallons
30225	Previous day Average Flow Rate - bbl/hr	Input Register	Floating Point Register (1 of 2)	bbl = US Oil Barrel = 42 Gallons
30226	Previous day Average Flow Rate - bbl/hr	Input Register	Floating Point Register (2 of 2)	bbl = US Oil Barrel = 42 Gallons
30227	Previous day Average Flow Rate - bbl/day	Input Register	Floating Point Register (1 of 2)	bbl = US Oil Barrel = 42 Gallons
30228	Previous day Average Flow Rate - bbl/day	Input Register	Floating Point Register (2 of 2)	bbl = US Oil Barrel = 42 Gallons
30301	Volume Total - Gallons	Input Register	Floating Point Register (1 of 2)	
30302	Volume Total - Gallons	Input Register	Floating Point Register (2 of 2)	



UF AV5500 Area-Velocity Flow Meter

Register Address	Description	Register Type	Format Type	Comments
30303	Volume Total - Liters	Input Register	Floating Point Register (1 of 2)	
30304	Volume Total - Liters	Input Register	Floating Point Register (2 of 2)	
30305	Volume Total - ft ³	Input Register	Floating Point Register (1 of 2)	
30306	Volume Total - ft ³	Input Register	Floating Point Register (2 of 2)	
30307	Volume Total - m ³	Input Register	Floating Point Register (1 of 2)	
30308	Volume Total - m ³	Input Register	Floating Point Register (2 of 2)	
30309	Volume Total - USMG	Input Register	Floating Point Register (1 of 2)	USMG = US Million Gallons
30310	Volume Total - USMG	Input Register	Floating Point Register (2 of 2)	USMG = US Million Gallons
30311	Volume Total - IG	Input Register	Floating Point Register (1 of 2)	IG = Imperial Gallons
30312	Volume Total - IG	Input Register	Floating Point Register (2 of 2)	IG = Imperial Gallons
30313	Volume Total - IMG	Input Register	Floating Point Register (1 of 2)	IMG = Imperial Million Gallons
30314	Volume Total - IMG	Input Register	Floating Point Register (2 of 2)	IMG = Imperial Million Gallons
30315	Volume Total - bbl	Input Register	Floating Point Register (1 of 2)	bbl = US Oil Barrel = 42 Gallons
30316	Volume Total - bbl	Input Register	Floating Point Register (2 of 2)	bbl = US Oil Barrel = 42 Gallons
30317	Previous day Volume Total - Gallons	Input Register	Floating Point Register (1 of 2)	
30318	Previous day Volume Total - Gallons	Input Register	Floating Point Register (2 of 2)	
30319	Previous day Volume Total - Liters	Input Register	Floating Point Register (1 of 2)	
30320	Previous day Volume Total - Liters	Input Register	Floating Point Register (2 of 2)	
30321	Previous day Volume Total - ft ³	Input Register	Floating Point Register (1 of 2)	
30322	Previous day Volume Total - ft ³	Input Register	Floating Point Register (2 of 2)	
30323	Previous day Volume Total - m ³	Input Register	Floating Point Register (1 of 2)	
30324	Previous day Volume Total - m ³	Input Register	Floating Point Register (2 of 2)	
30325	Previous day Volume Total - USMG	Input Register	Floating Point Register (1 of 2)	USMG = US Million Gallons
30326	Previous day Volume Total - USMG	Input Register	Floating Point Register (2 of 2)	USMG = US Million Gallons



UF AV5500 Area-Velocity Flow Meter

Register Address	Description	Register Type	Format Type	Comments
30327	Previous day Volume Total - IG	Input Register	Floating Point Register (1 of 2)	IG = Imperial Gallons
30328	Previous day Volume Total - IG	Input Register	Floating Point Register (2 of 2)	IG = Imperial Gallons
30329	Previous day Volume Total - IMG	Input Register	Floating Point Register (1 of 2)	IMG = Imperial Million Gallons
30330	Previous day Volume Total - IMG	Input Register	Floating Point Register (2 of 2)	IMG = Imperial Million Gallons
30331	Previous day Volume Total - bbl	Input Register	Floating Point Register (1 of 2)	bbl = US Oil Barrel = 42 Gallons
30332	Previous day Volume Total - bbl	Input Register	Floating Point Register (2 of 2)	bbl = US Oil Barrel = 42 Gallons
30501	Sensor Range - inches	Input Register	Floating Point Register (1 of 2)	Only used when through-air sensor is installed.
30502	Sensor Range - inches	Input Register	Floating Point Register (2 of 2)	Only used when through-air sensor is installed.
30503	Sensor Range - feet	Input Register	Floating Point Register (1 of 2)	Only used when through-air sensor is installed.
30504	Sensor Range - feet	Input Register	Floating Point Register (2 of 2)	Only used when through-air sensor is installed.
30505	Sensor Range - mm	Input Register	Floating Point Register (1 of 2)	Only used when through-air sensor is installed.
30506	Sensor Range - mm	Input Register	Floating Point Register (2 of 2)	Only used when through-air sensor is installed.
30507	Sensor Range - meters	Input Register	Floating Point Register (1 of 2)	Only used when through-air sensor is installed.
30508	Sensor Range - meters	Input Register	Floating Point Register (2 of 2)	Only used when through-air sensor is installed.
30525	Sensor Level - inches	Input Register	Floating Point Register (1 of 2)	
30526	Sensor Level - inches	Input Register	Floating Point Register (2 of 2)	
30527	Sensor Level - feet	Input Register	Floating Point Register (1 of 2)	
30528	Sensor Level - feet	Input Register	Floating Point Register (2 of 2)	
30529	Sensor Level - mm	Input Register	Floating Point Register (1 of 2)	
30530	Sensor Level - mm	Input Register	Floating Point Register (2 of 2)	
30531	Sensor Level - meters	Input Register	Floating Point Register (1 of 2)	
30532	Sensor Level - meters	Input Register	Floating Point Register (2 of 2)	
30709	Flow Temperature - F	Input Register	Floating Point Register (1 of 2)	
30710	Flow Temperature - F	Input Register	Floating Point Register (2 of 2)	

Register Address	Description	Register Type	Format Type	Comments
30711	Flow Temperature - C	Input Register	Floating Point Register (1 of 2)	
30712	Flow Temperature - C	Input Register	Floating Point Register (2 of 2)	
30901	Signal Strength - %	Input Register	Integer	0-100
30904	Run Hours	Input Register	Floating Point Register (1 of 2)	
30905	Run Hours	Input Register	Floating Point Register (2 of 2)	
30923	Sensor Status	Input Register	Index (0-10)	0 = Sensor Good 4 = Sensor Open 5 = Sensor Short 7 = Low Signal
30925	Logging Status	Input Register	Index (0-2)	0 = Stopped 1 = Active 2 = Full
30926	Logging Used - %	Input Register	Floating Point Register (1 of 2)	
30927	Logging Used - %	Input Register	Floating Point Register (2 of 2)	
30928	mA Output 1 - 4mA Value	Input Register	Floating Point Register (1 of 2)	
30929	mA Output 1 - 4mA Value	Input Register	Floating Point Register (2 of 2)	
30930	mA Output 1 - 20mA Value	Input Register	Floating Point Register (1 of 2)	
30931	mA Output 1 - 20mA Value	Input Register	Floating Point Register (2 of 2)	
30932	mA Output 2 - 4mA Value	Input Register	Floating Point Register (1 of 2)	
30933	mA Output 2 - 4mA Value	Input Register	Floating Point Register (2 of 2)	
30934	mA Output 2 - 20mA Value	Input Register	Floating Point Register (1 of 2)	
30935	mA Output 2 - 20mA Value	Input Register	Floating Point Register (2 of 2)	
30936	mA Output 3 - 4mA Value	Input Register	Floating Point Register (1 of 2)	
30937	mA Output 3 - 4mA Value	Input Register	Floating Point Register (2 of 2)	
30938	mA Output 3 - 20mA Value	Input Register	Floating Point Register (1 of 2)	
30939	mA Output 3 - 20mA Value	Input Register	Floating Point Register (2 of 2)	
30940	mA Output 1 - Output Level	Input Register	Floating Point Register (1 of 2)	Current mA feedback on output # 1

Register Address	Description	Register Type	Format Type		Comments
30941	mA Output 1 - Output Level	Input Register	Floating Point Register (2 of 2)		Current mA feedback on output # 1
30942	mA Output 2 - Output Level	Input Register	Floating Point Register (1 of 2)		Current mA feedback on output # 2
30943	mA Output 2 - Output Level	Input Register	Floating Point Register (2 of 2)		Current mA feedback on output # 2
30944	mA Output 3 - Output Level	Input Register	Floating Point Register (1 of 2)		Current mA feedback on output # 3
30945	mA Output 3 - Output Level	Input Register	Floating Point Register (2 of 2)		Current mA feedback on output # 3
30947	Velocity Units	Input Register	Index (0 to 1)	0 = Feet per Second 1 = Meter per Second	
30948	Flow Units	Input Register	Index (0 to 31)	0 = US Gallons per Minute 1 = Litres per Second 2 = Cubic Feet per Minute 3 = Cubic Meters per Hour 4 = US Gallons per Second 5 = US Gallons per Hour 6 = US Gallons per Day 7 = Cubic Feet per Second 8 = Cubic Feet per Hour 9 = Cubic Feet per Day 10 = US Million Gallons per Second 11 = US Million Gallons per Minute 12 = US Million Gallons per Hour 13 = US Million Gallons per Day 14 = Litres per Minute 15 = Litres per Hour 16 = Litres per Day 17 = Cubic Meters per Second 18 = Cubic Meters per Minute 19 = Cubic Meters per Day 20 = Imperial Gallons per Second 21 = Imperial Gallons per Minute 22 = Imperial Gallons per Hour 23 = Imperial Gallons per Day 24 = Imperial Million Gallons per Second 25 = Imperial Million Gallons per Minute 26 = Imperial Million Gallons per Hour 27 = Imperial Million Gallons per Day 28 = Barrels per Second 29 = Barrels per Minute 30 = Barrels per Hour 31 = Barrels per Day	
30949	Linear Units	Input Register	Index (0 to 3)	0 = Feet 1 = Inches 2 = Millimeters 3 = Meters	



UF AV5500 Area-Velocity Flow Meter

Register Address	Description	Register Type	Format Type		Comments
30950	Volume Units	Input Register	Index (0 to 7)	0 = Cubic Feet 1 = US Gallons 2 = US Million Gallons 3 = Imperial Gallons 4 = Imperial Million Gallons 5 = Cubic Meters 6 = Litre 7 = Barrel	
30951	Time Units	Input Register	Index (0 to 3)	0 = Second 1 = Minute 2 = Hour 3 = Day	
30961	Echo Confidence	Input Register	Integer		
30963	Confidence	Input Register	Integer	Tech's Menu Value	
30964	Direction	Input Register	Integer	Tech's Menu Value	
30965	Pot 1	Input Register	Integer	Tech's Menu Value	
30966	Peak to Peak	Input Register	Integer	Tech's Menu Value	
30967	Correlation Strength	Input Register	Integer	Tech's Menu Value	

ENCLOSURE HEATER AND THERMOSTAT - Option TH

Instruments can be factory-equipped with an Enclosure Heater and Thermostat or the module can be customer-installed. The Thermostat is factory set to turn ON at 40°F (4.5°C) and OFF at 60°F (15.5°C). Power consumption is 15 Watts.

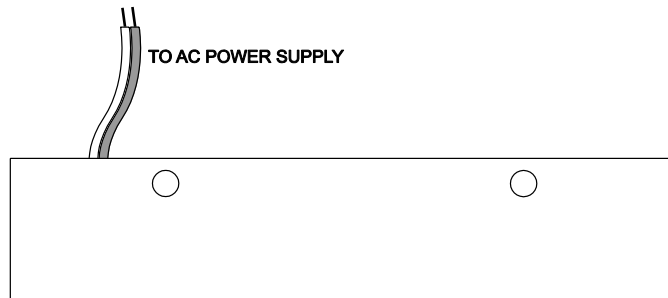

ENCLOSURE SUNSCREEN - Option SCR

Do not mount instrument electronics in direct sunlight. Overheating will reduce the life of electronic components and condensate may form during the heat/cool cycles and cause electrical shorts.

Note:

Exposure to direct sunlight can cause overheating and moisture condensation which will reduce the operating life of electronics.

Protect Instruments from direct sunlight with this iridite finished aluminum sun screen (Greyline Option SCR).

Seal conduit entries with caulking compound to further reduce moisture condensation.

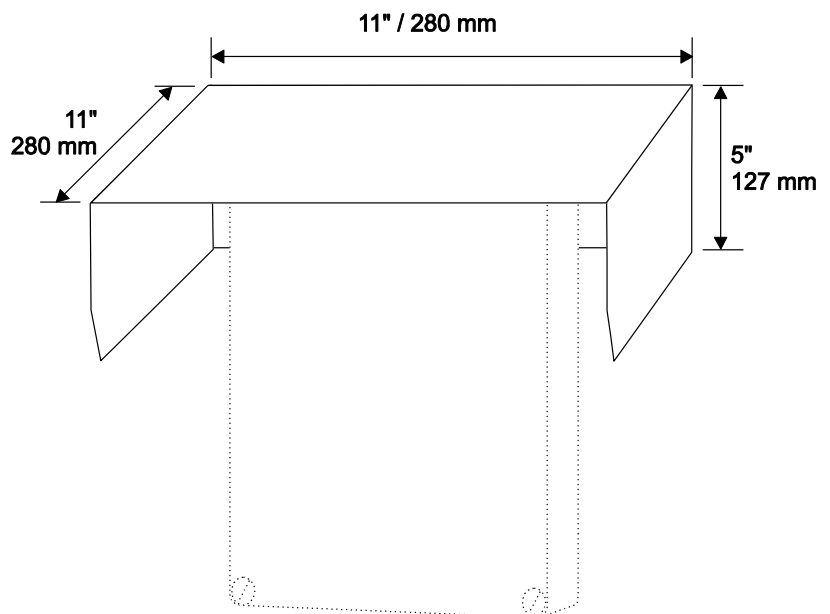

**POWER INPUT OPTION
9-32VDC**

UF AV5500 Flow Meters may be ordered factory-configured for 9-32VDC power input.

CONNECTIONS:

POWER INPUT: Connect 9-32VDC to the + and - terminals. The Power Input GND terminal must be connected to the nearest Ground pole. A 1-amp fuse in line is recommended.

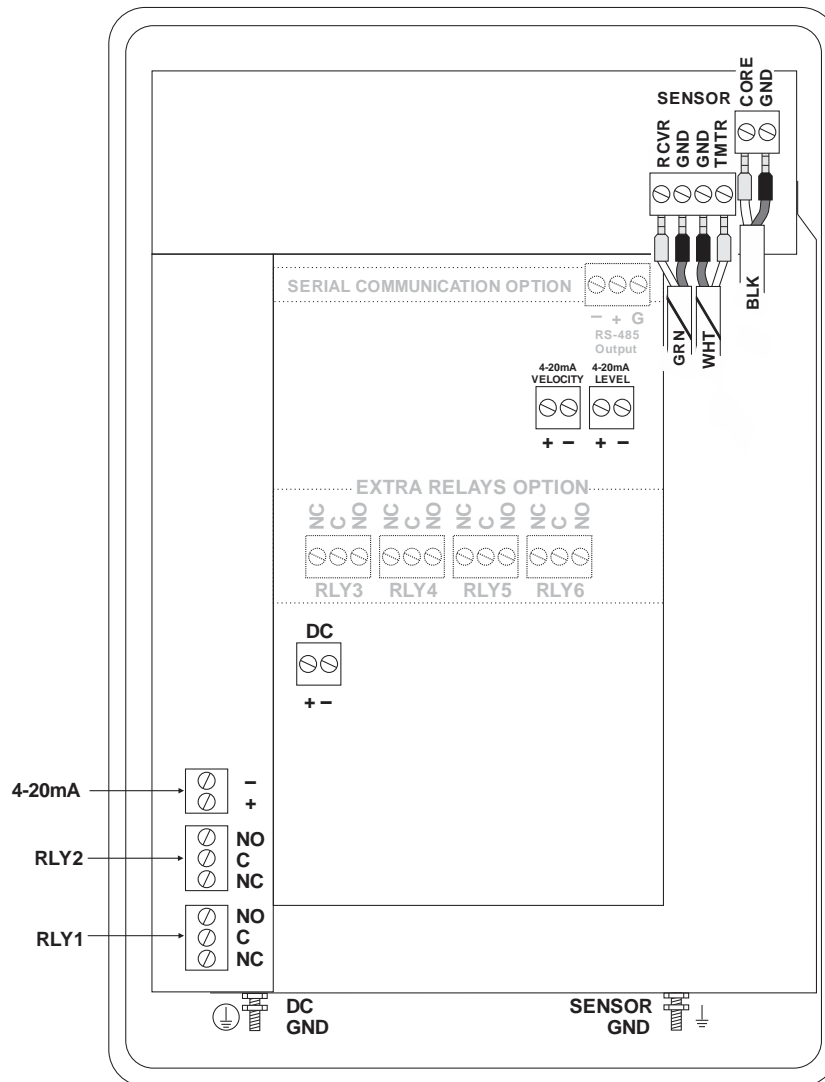

SPECIFICATIONS

- Channel Types:** Round pipe, Rectangular, trapezoid, egg or custom shapes
- Electronics Enclosure:** Watertight and dust tight NEMA4X (IP 66) polycarbonate with clear, shatterproof cover
- Accuracy:** Level: $\pm 0.25\%$ of reading or $\pm 0.08"$, whichever is greater. Repeatability & Linearity 0.1%
Velocity: $\pm 2\%$ of reading or ± 0.04 ft/sec, whichever is greater. Requires solids or bubbles minimum size of 100 microns, minimum concentration 75 ppm. Repeatability & Linearity 0.5%
- Display:** White, back-lit matrix – displays flow rate, totalizer, relay states, operating mode and calibration menu
- Programming:** Built-in 5-key calibrator with English, French or Spanish language selection
- Power Input:** 100-240VAC, 50/60Hz, 10VA maximum.
Optional 9-32VDC, 10 WATTS maximum
- Outputs:** 3 Isolated 4-20mA, 1000 ohm, (Flow, Level and Velocity) or 0-5VDC by menu selection
- Control Relays:** 2 Relays, form 'C' dry contacts rated 5 amp SPDT; programmable for flow proportional pulse (sampler/totalizer), flow and/or level alarm
- Data Logging:** Programmable 6.5-million point data capacity, time and date stamped plus formatted flow reports including Total, Average, Minimum, Maximum and times of occurrence. Includes USB output to Flash Drives and Windows software
- Operating Temp. (electronics):** -5 to 140°F (-20° to 60°C)
- Approximate Shipping Weight:** 10 lbs (4.5 Kg)
- Approvals:** CE, CSA/UL/EN 61010-1

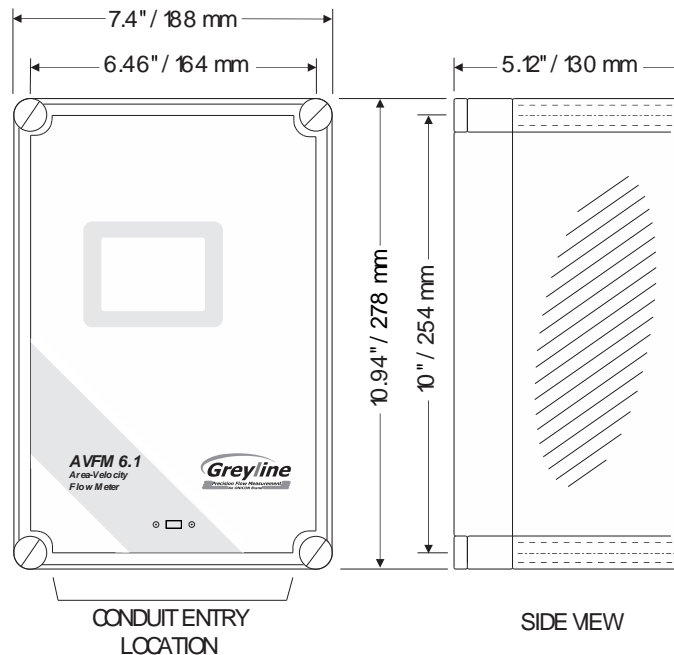

QZ02L Sensor

- Velocity Measurement Range:** 0.1 to 20 ft/sec (0.03 to 6.2 m/sec) and reverse flow to -5 ft/sec (-1.5 m/sec) in fluids containing bubbles or solids with a minimum size of 100 microns and a minimum concentration of 75 ppm to act as acoustic reflectors.
- Level Measurement Range:** Minimum Head: 1 in (25.4 mm). Maximum Head: 15 ft. (4.57 m)
- Operating Temperature:** 5 to 175°F (-15 to 80°C)
- Exposed Materials:** 316 stainless steel, epoxy resin, polyurethane
- Sensor Cable:** 25 ft. (7.6 m) submersible polyurethane jacket, shielded, 3-coaxial
- Sensor Mounting:** includes MB-QZ stainless steel mounting bracket
- Temperature Compensation:** Automatic, continuous

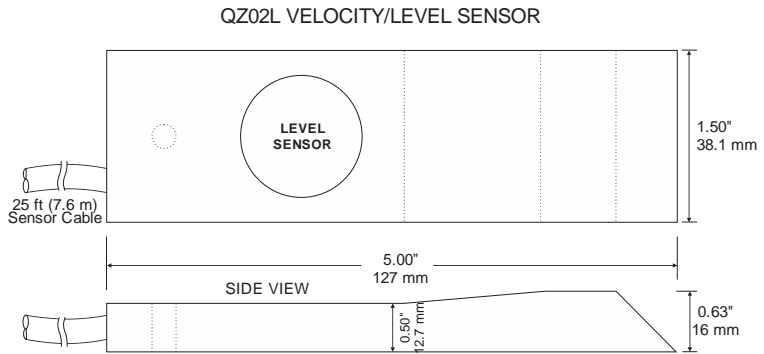
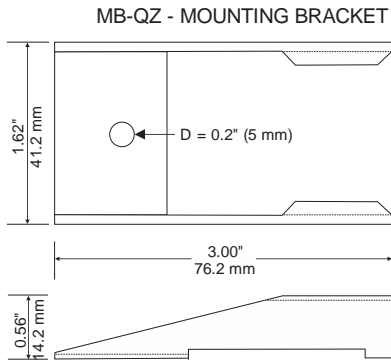

Optional (Velocity only) Sensor QZ02L-B

- Minimum Velocity:** 0.1 ft/sec (0.03 m/sec)
- Maximum Velocity:** 20 ft/sec (6.2 m/sec) [reverse flow to -5 ft/sec (-1.5 m/sec)]
- Operating Temperature:** 5 to 150°F (-15 to 65°C)
- Exposed Materials:** PVC, epoxy resin, polyurethane, ultem
- Sensor Cable:** 25 ft (7.6 m) submersible polyurethane jacket, shielded, 3-coaxial
- Hazardous Rating:** CSA rated Intrinsically Safe Class I, Div 1, Groups C,D, Class II, Div 1, Groups E,F,G, with optional Intrinsic Safety Barrier

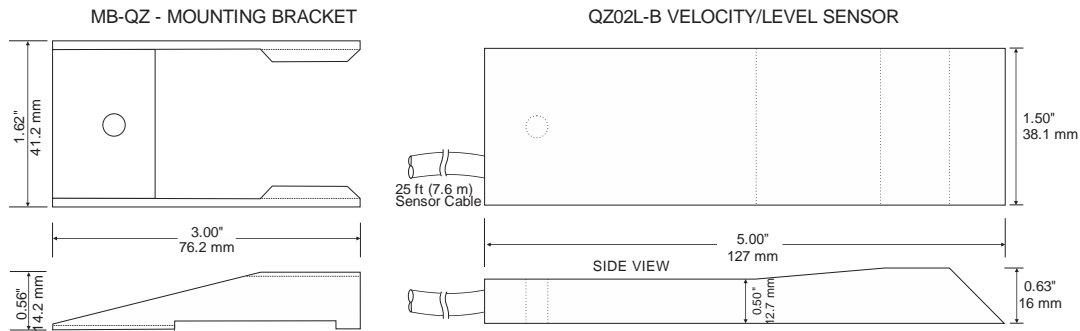

Optional (Level only) Sensor PZ15-LP

- Maximum Range:** 15 ft (4.57 m)
- Minimum Range:** 8" (203.2 mm)
- Beam Angle:** 8°
- Operating Temperature:** -40 to 150°F (-40 to 65°C)
- Exposed Materials:** Sensor – PVC; Mounting Bracket - 316 Stainless
- Hazardous Rating:** Standard: Certified non-incendive for Class 1 Div 2, Groups A,B,C,D hazardous locations. Optional: CSA rated Intrinsically Safe Class I, Div 1, Groups C,D, Class II, Div 1, Groups E,F,G with optional Intrinsic Safety Barrier

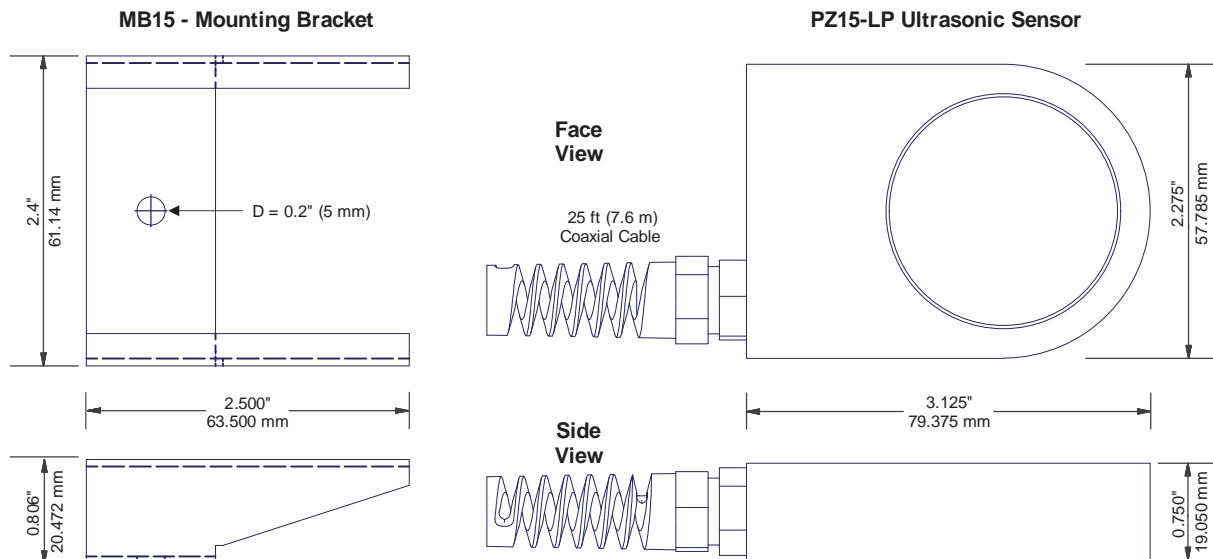

Dual Non-Contacting Sensor Configuration

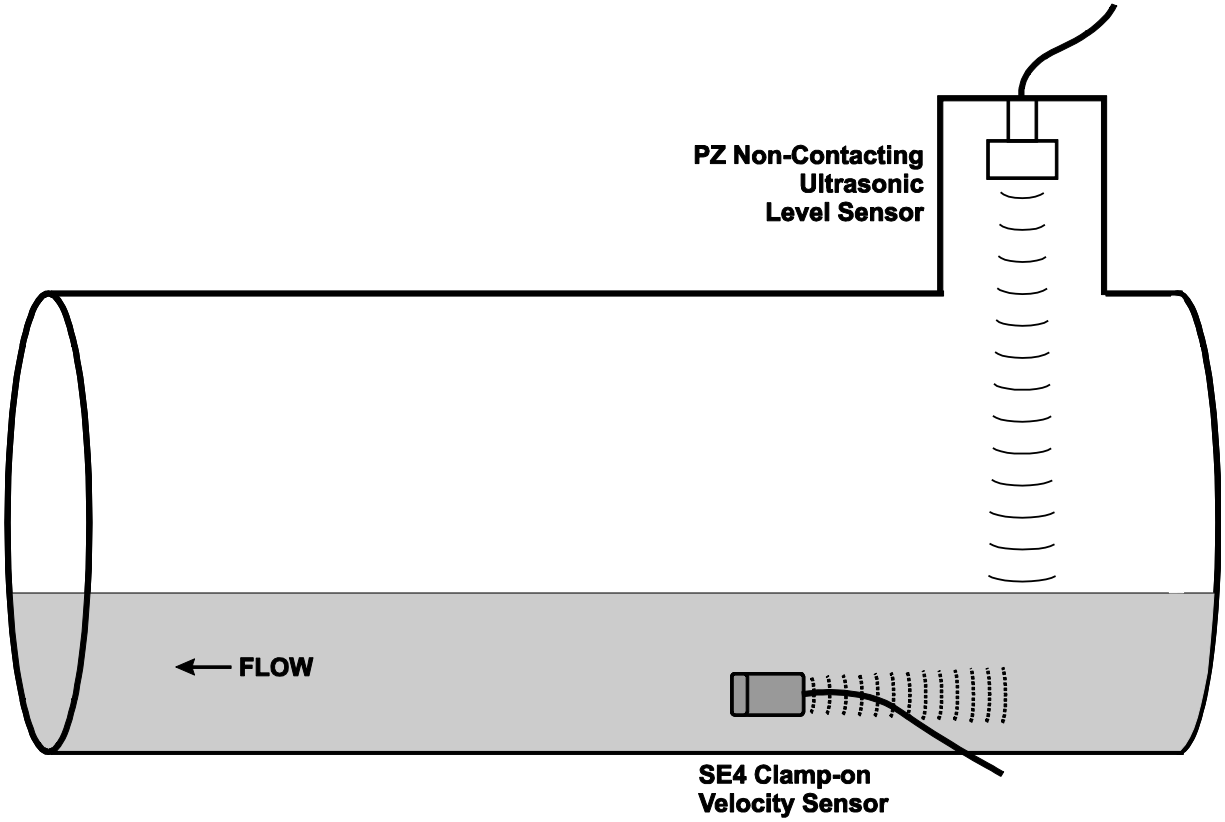

CONNECTIONS
Dual Sensor Configuration

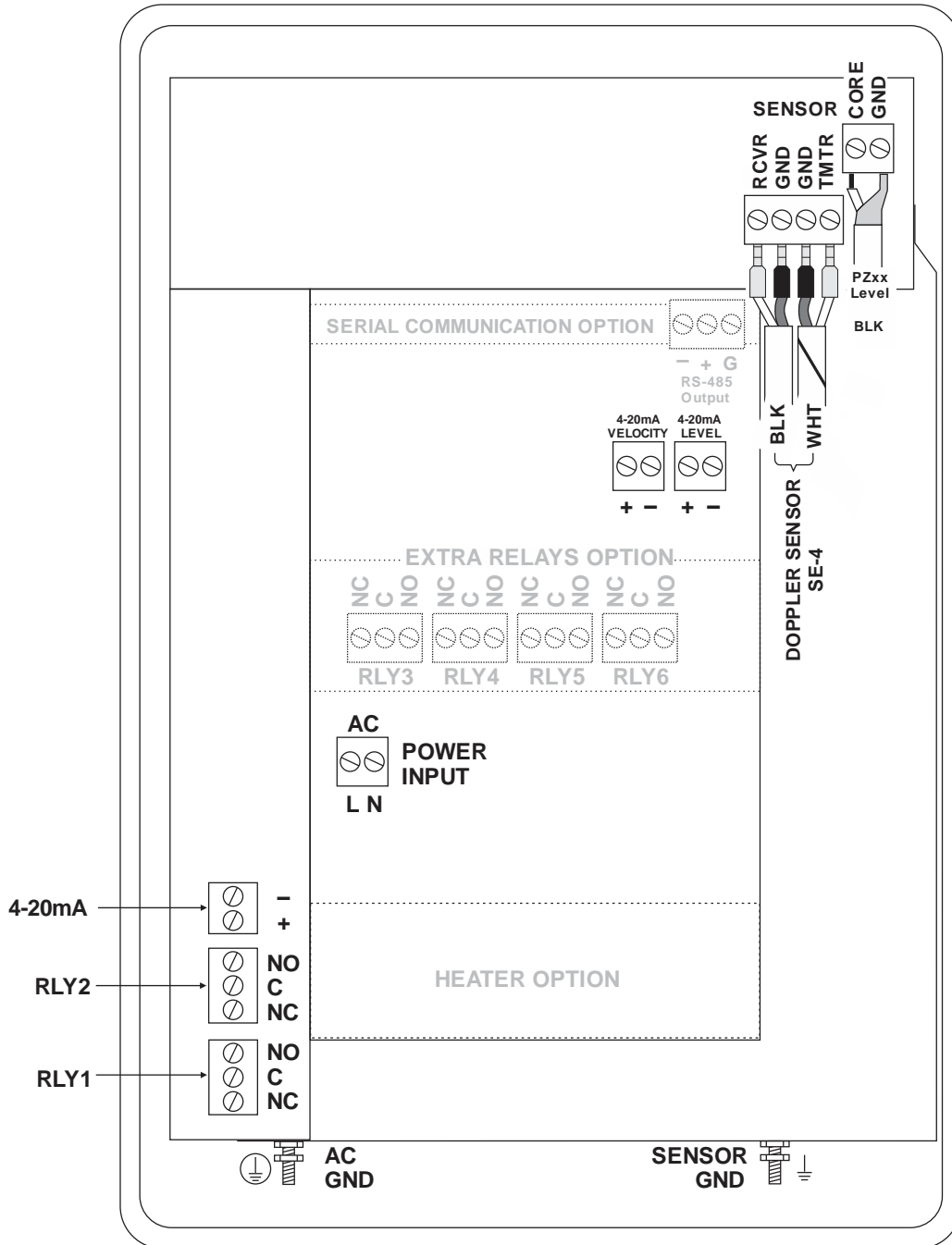

PZxx FLANGE SENSOR MOUNTING METHODS IN ROUND PIPES

Notes:

1. Use the 3/4" NPT "Isolation Coupling" supplied and hand tighten only. Do not clamp sensor body or stem.
2. Do not mount sensor or cover flange in direct sunlight.
3. Extend sensor cable up to 500 ft (150 m) with RG62AU coaxial only and junction box.
4. Standpipe diameter as large as possible, typical standpipe: 6" / 150 mm diameter, 12" – 16" (300 – 500 mm) height.

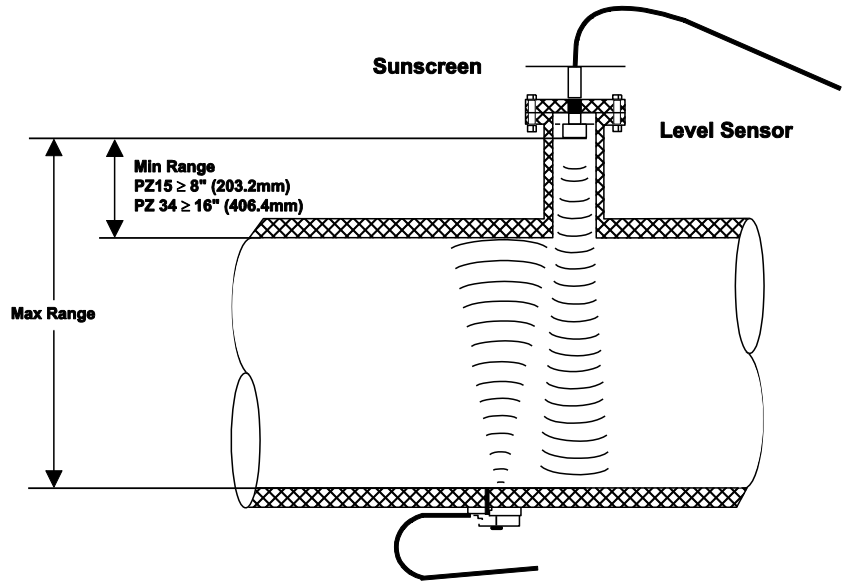

Use a Sensor Sunscreen (option PZS) when sensor is installed indirect sunlight.

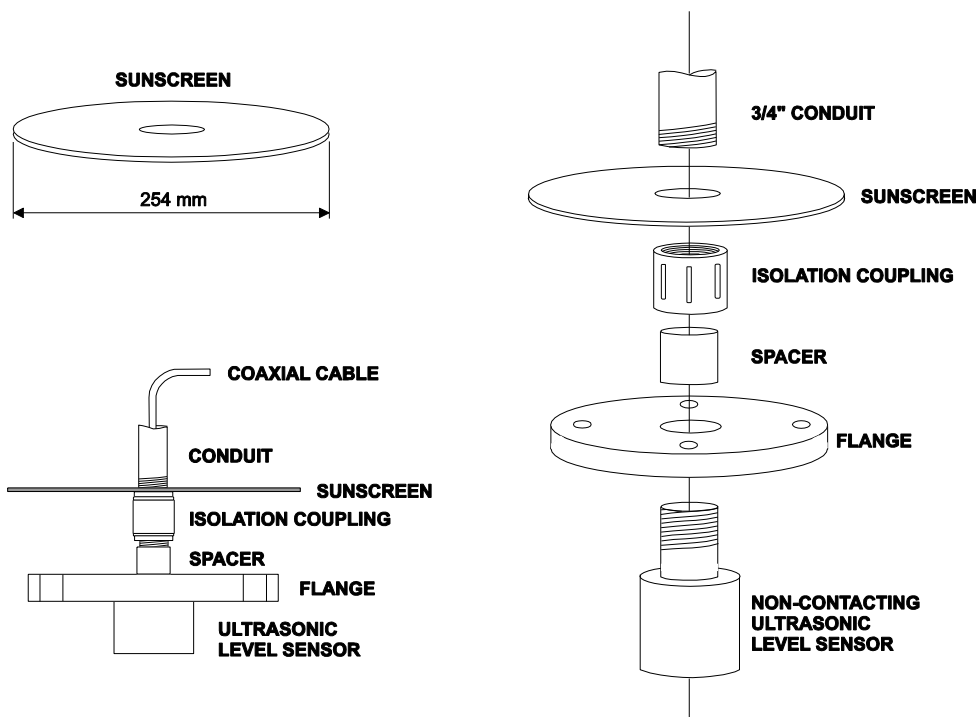

SE4 SENSOR COUPLING Dual Sensor Configuration

For permanent or temporary bonding, the following are recommended:

- a) Super Lube ® (supplied)
Additional supply: order Micronics Option CC-SL30
- b) High Temperature compound
Additional supply: order Micronics Option CC-SL30HT
- c) Electrocardiograph gel
- d) Petroleum gel (Vaseline)

The above are arranged in their order of preferred application.
c & d are only good for temporary bonding at room temperature.
DO NOT USE: Silicon RTV caulking compound (silicon rubber).

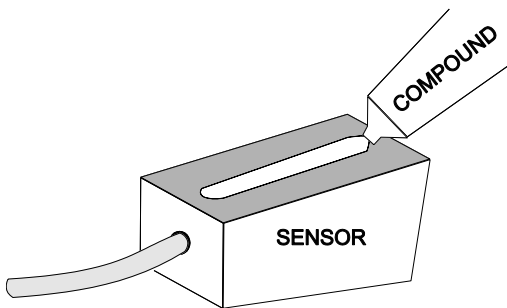

Use the PC4 pipe clamp (supplied) as illustrated below, or use a loop of electrical tape for temporary mounting. Apply coupling compound to the coloured face of the sensor. A bead, similar to toothpaste on a toothbrush, is ideal. Do not overtighten (crush the sensor).

The sensor must be fixed securely to the pipe with coupling material between the sensor face and the pipe. Sensor installation with excessive coupling compound can result in gaps or voids in the coupling and cause errors or loss of signal. Insufficient coupling compound will create similar conditions.

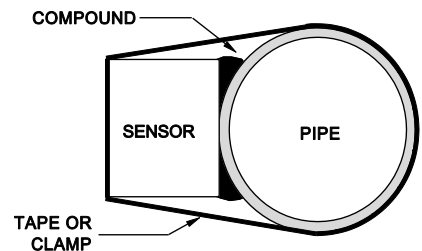

Over time, temporary coupling compounds (e.g. Petroleum Gel) may gradually sag away from the sensor resulting in reduced signal strength and finally complete loss of signal. Warm temperatures, moisture and vibration will accelerate this process. Super Lube ® as supplied with the UF AV5500 (and available from Micronics Limited) is recommended for permanent installations.

SE4 SENSOR MOUNTING
Dual Sensor Configuration

Prepare an area 2" wide by 4" long (50mm x 100mm) for sensor bonding by removing loose paint, scale and rust. The objective of site preparation is to eliminate any discontinuity between the sensor and the pipe wall, which would prevent acoustical coupling.

A PC4 Sensor Mounting Kit is supplied with each Micronics SE4 sensor. It includes recommended coupling compound in a plastic applicator and a stainless steel mounting bracket with adjustable pipe straps.

END VIEW

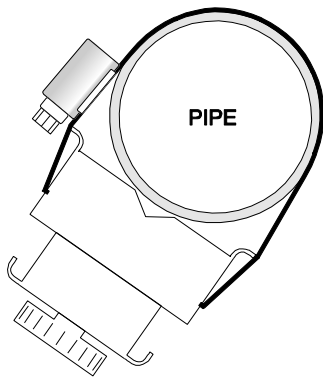

Additional stainless steel bands (by customer) may be combined to mount on pipes up to 180" / 4.5 m OD.

